

Slight

Sliding gate opener

CE

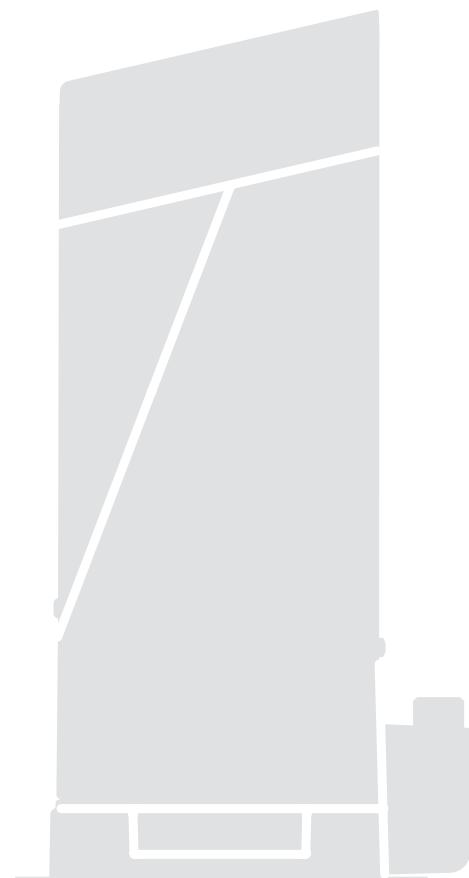

Instructions and warnings for installation and use

Nice

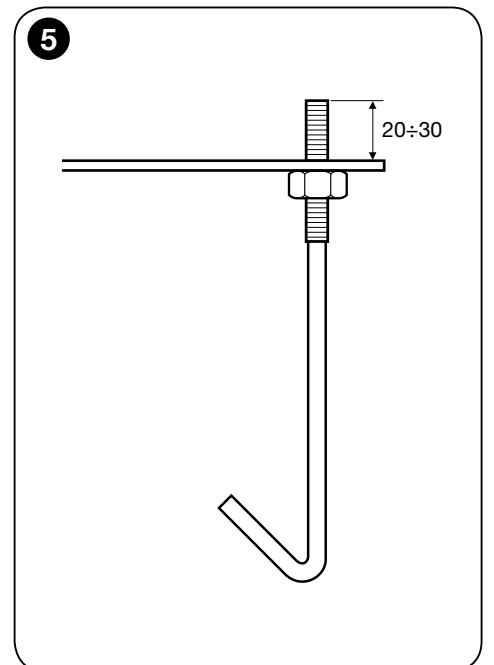
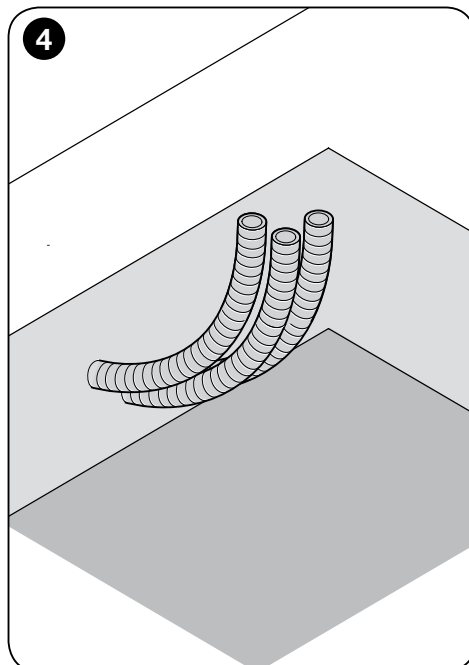
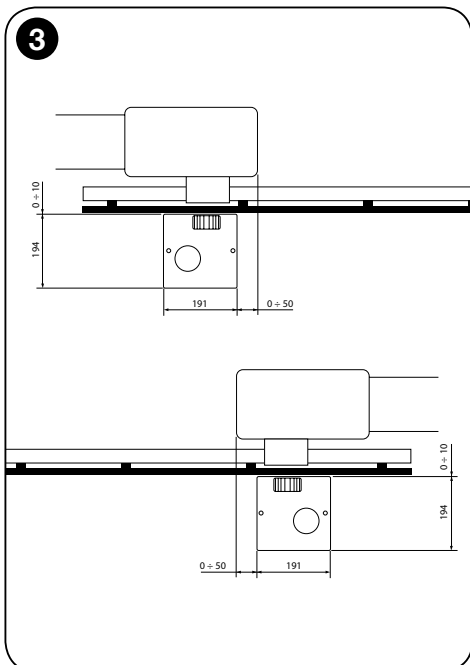
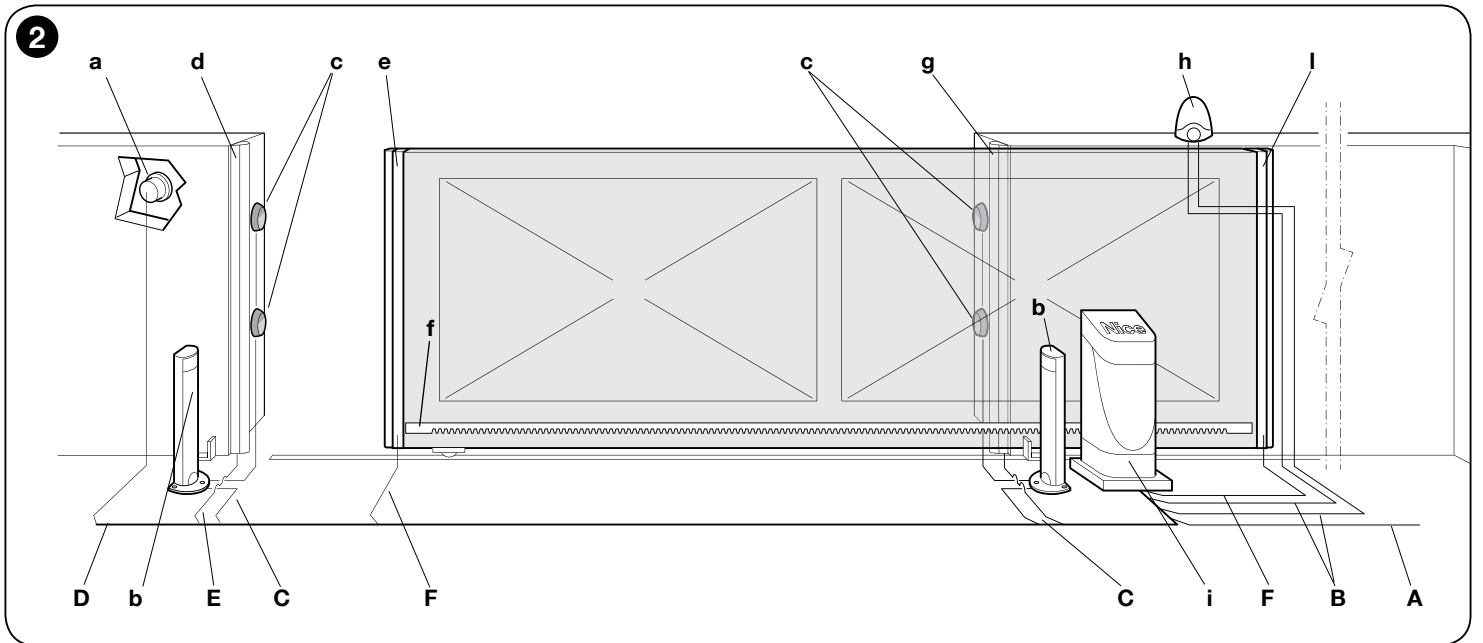
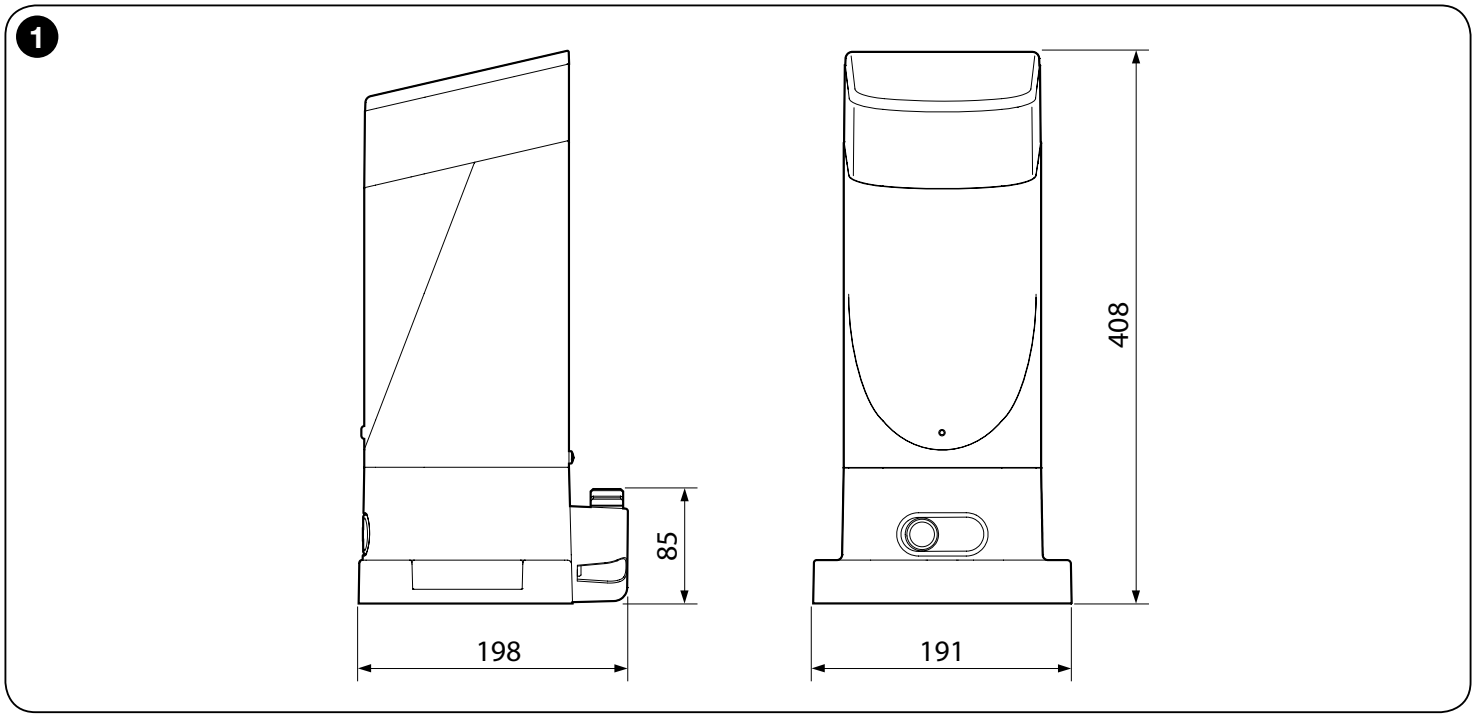

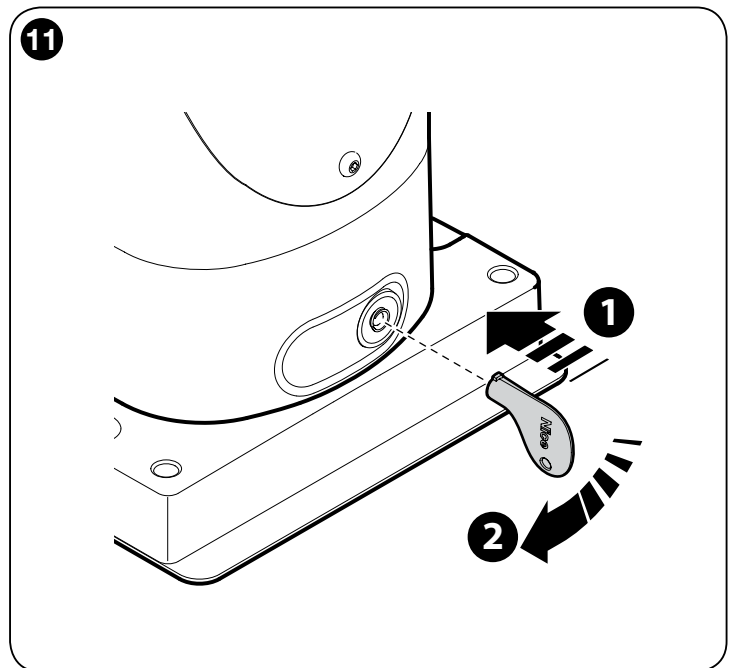
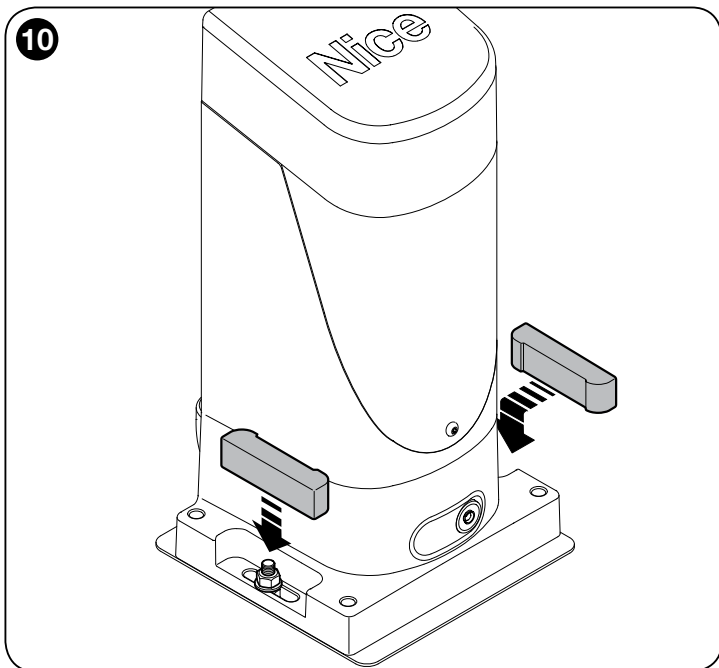
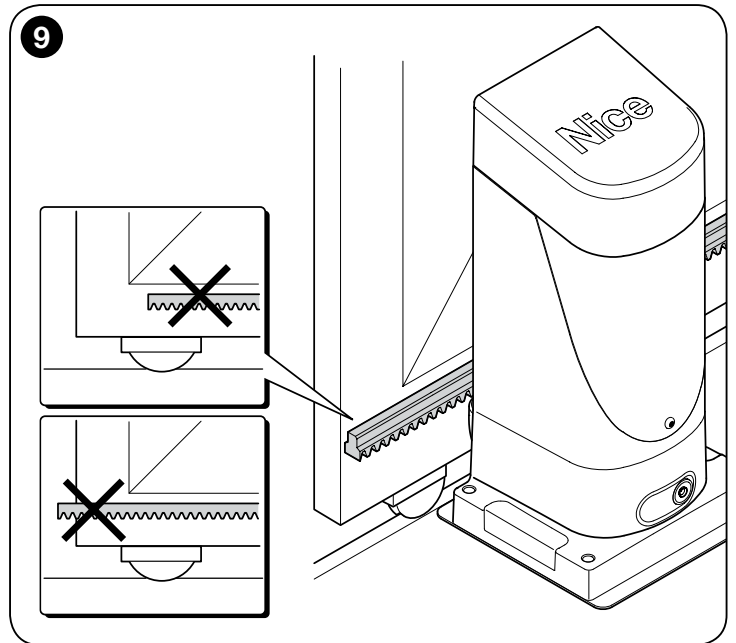
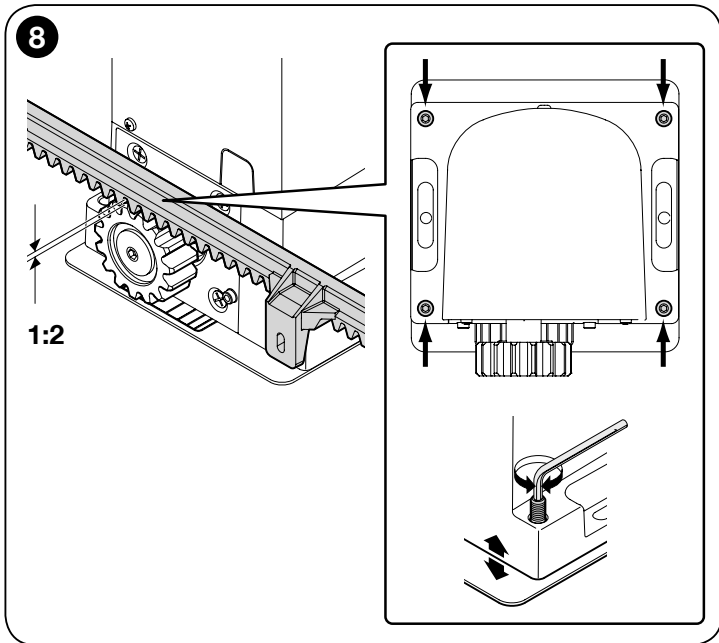
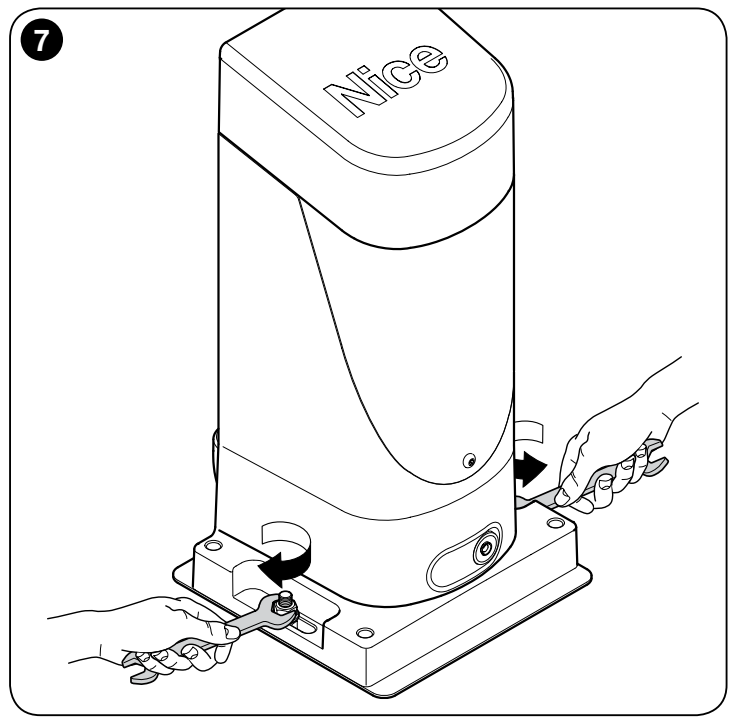
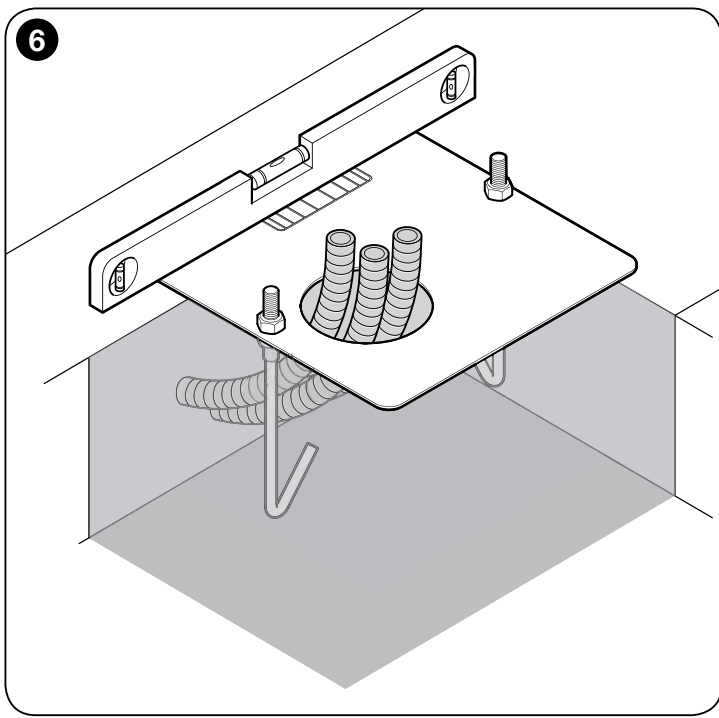

12

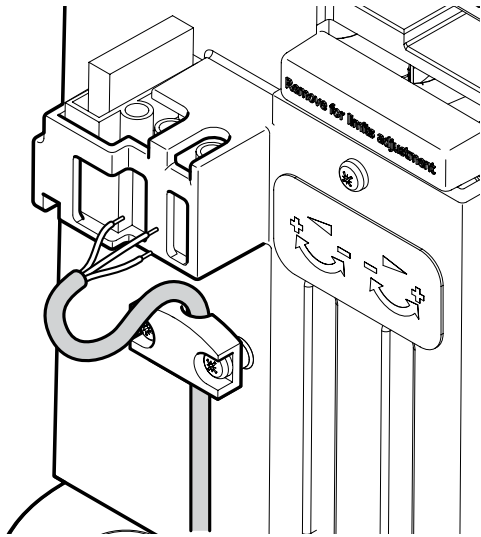

13

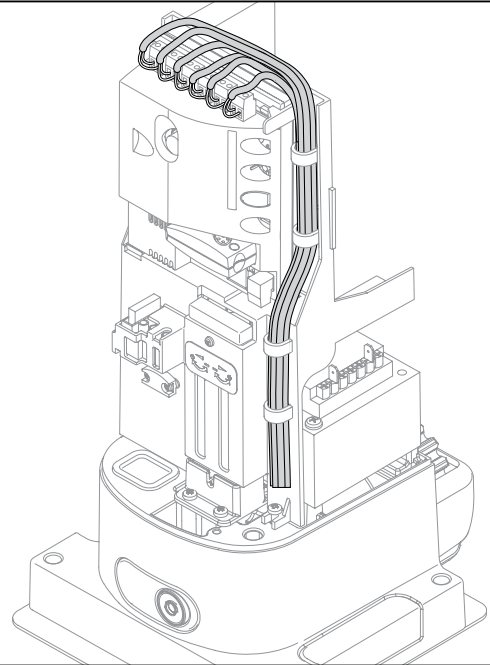

14

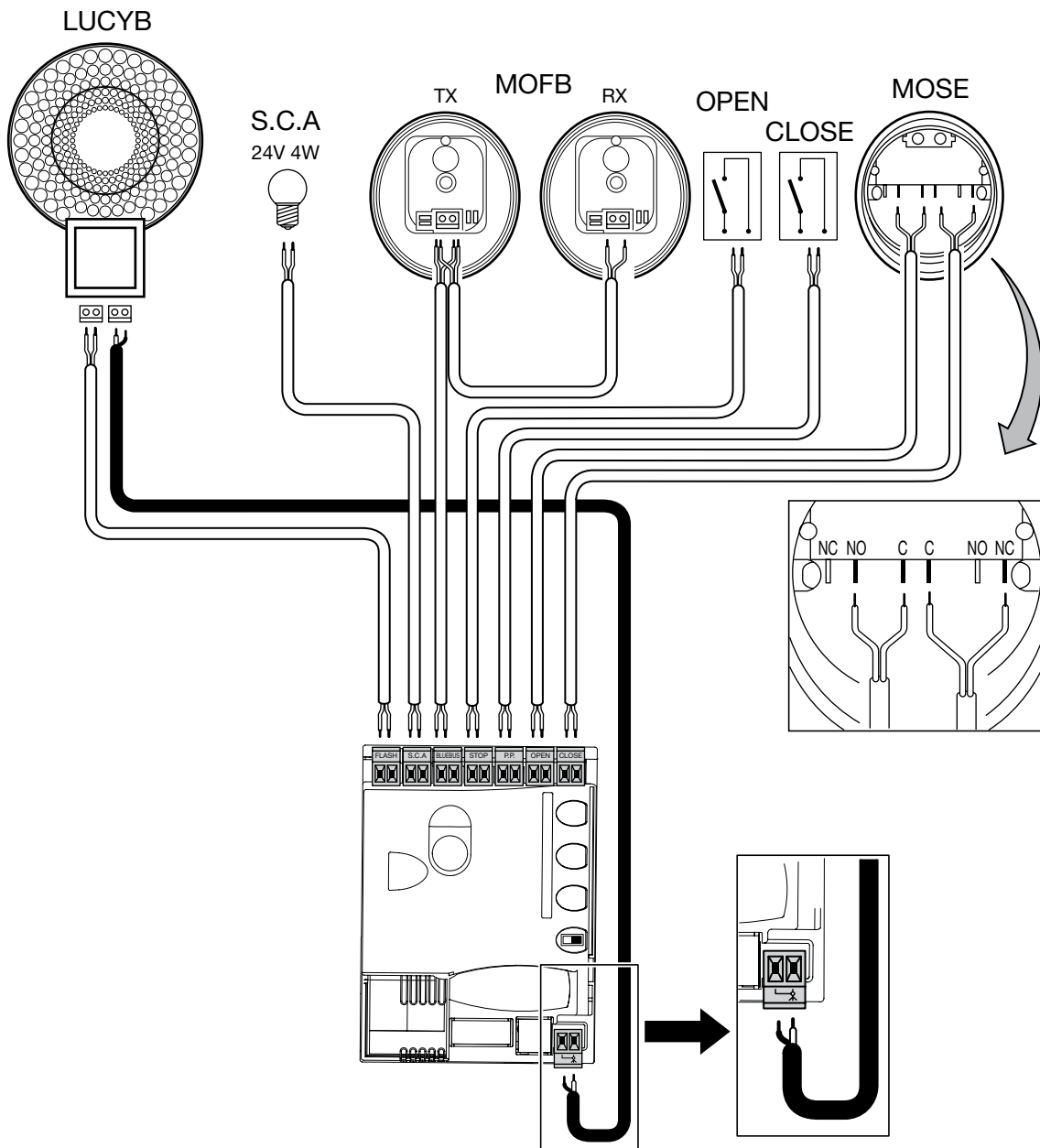

15

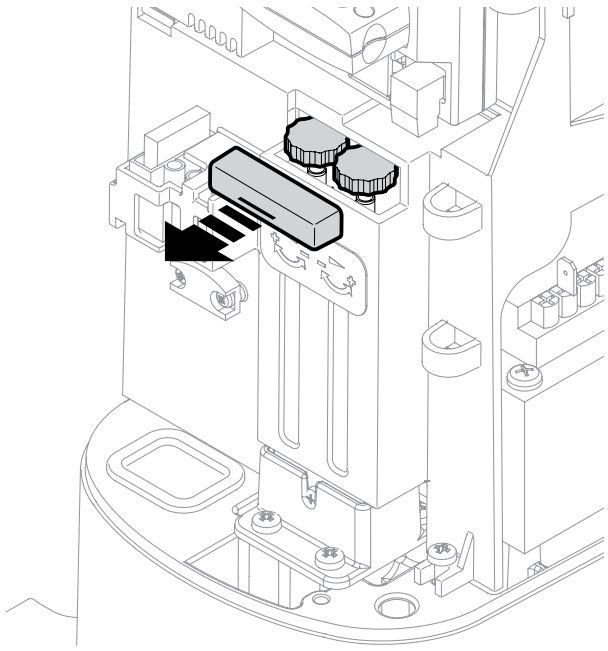

16

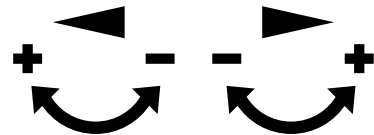
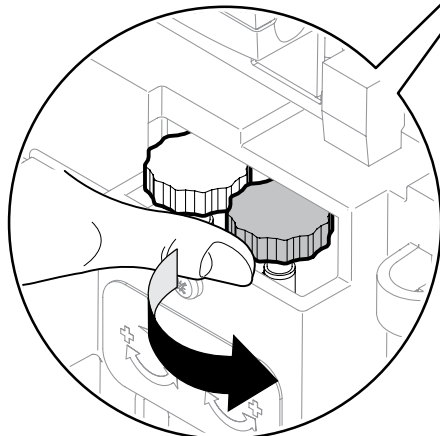
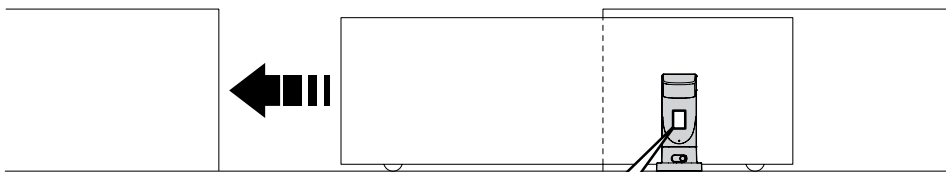
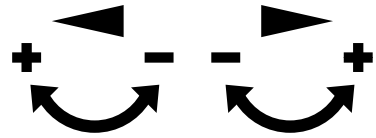
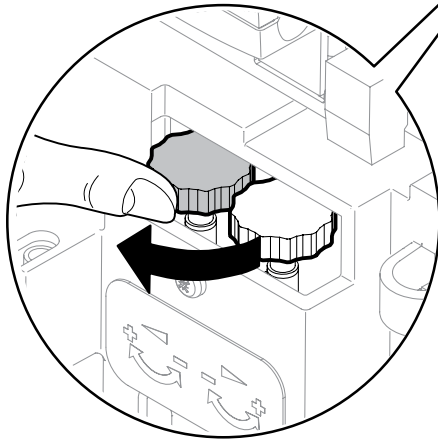
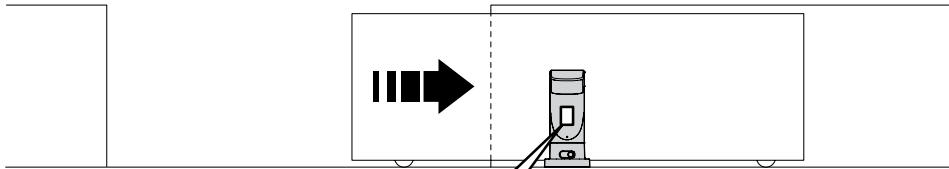
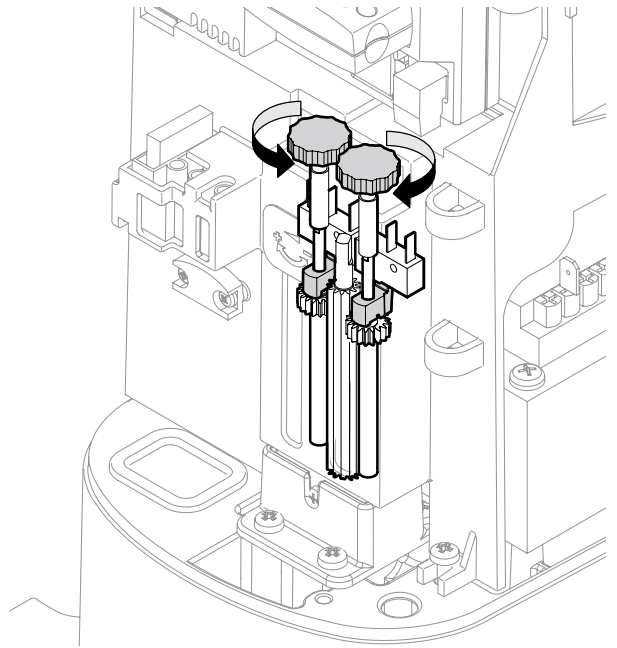

17

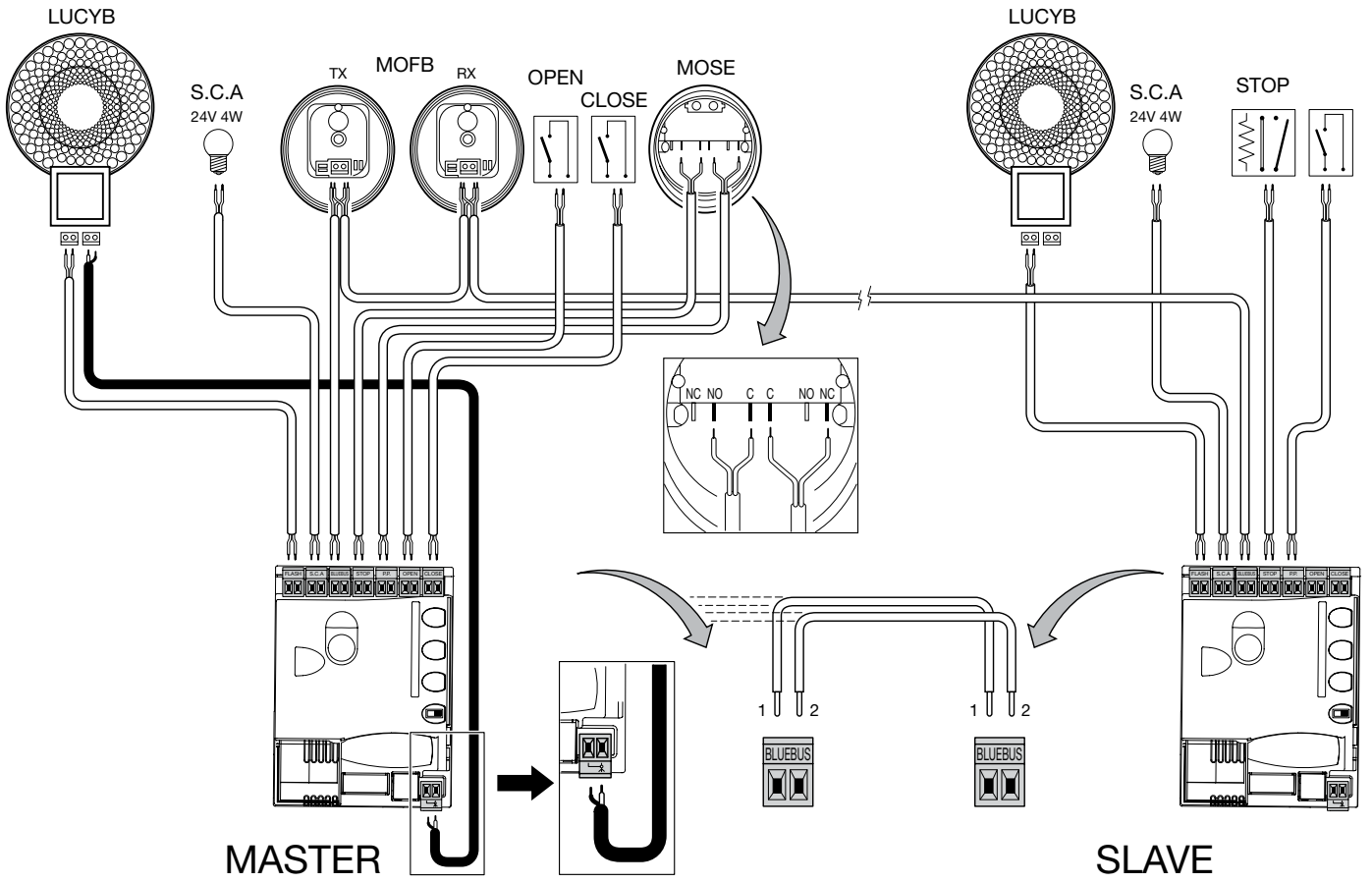

18

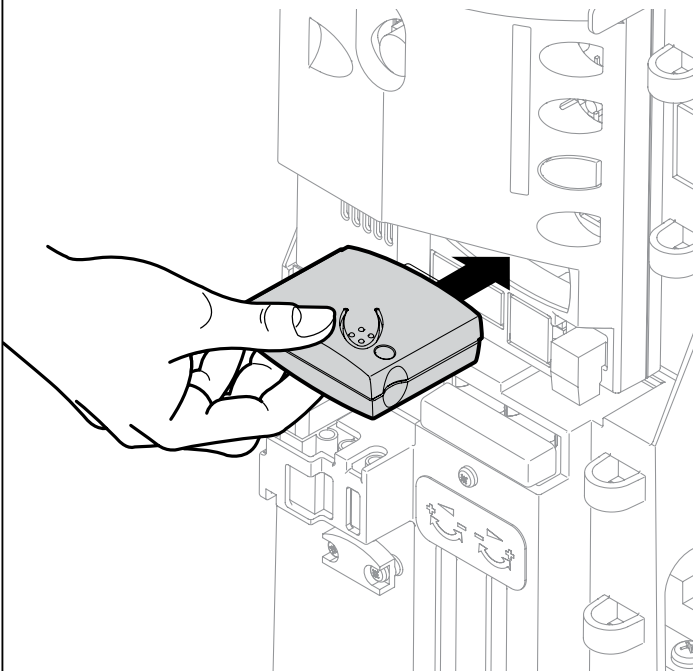

19

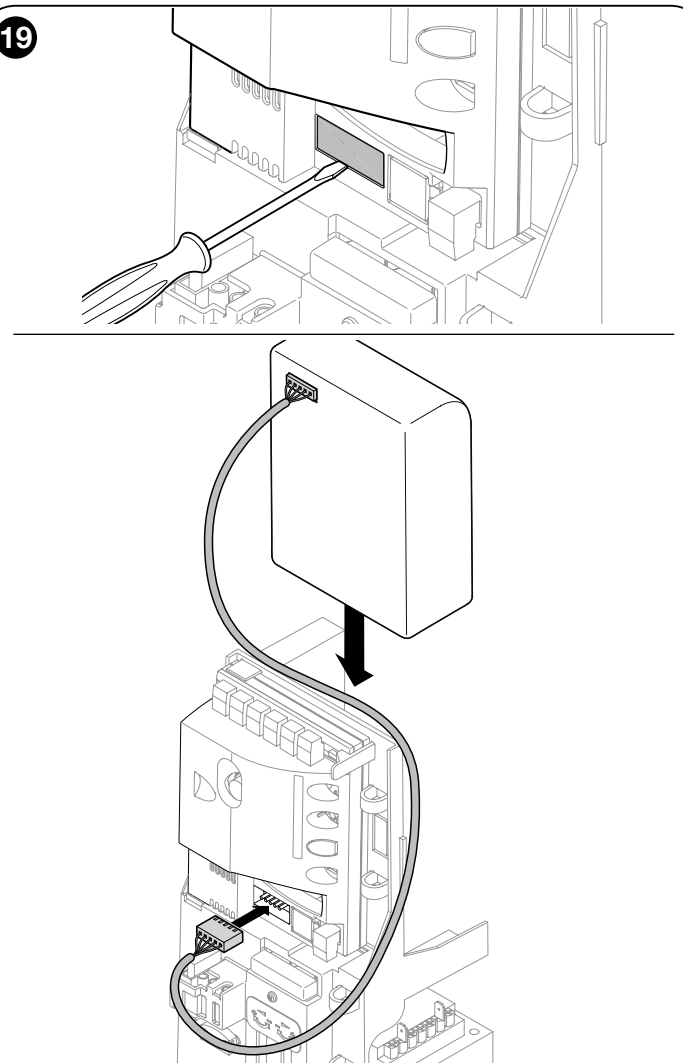

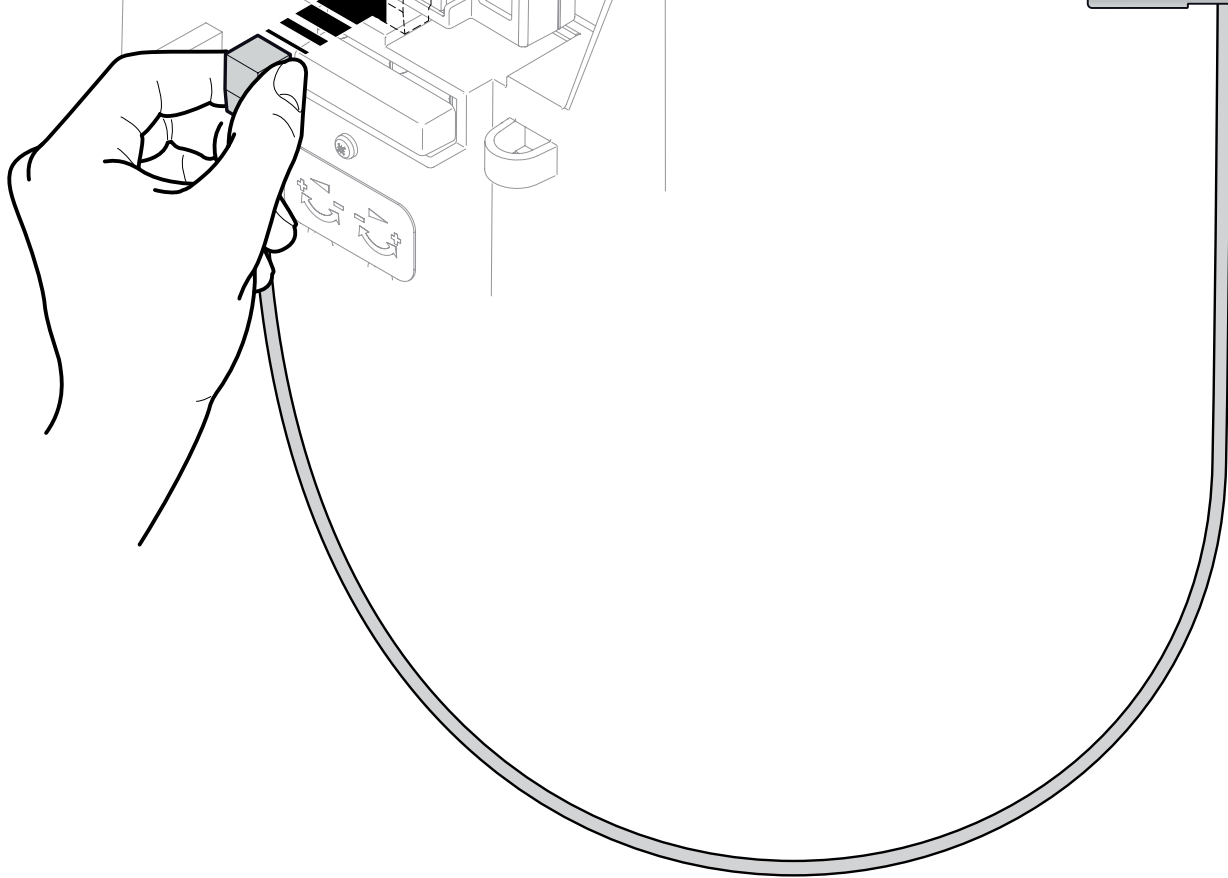
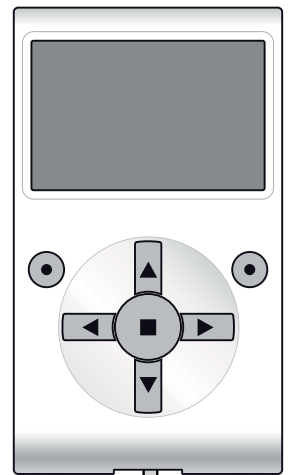
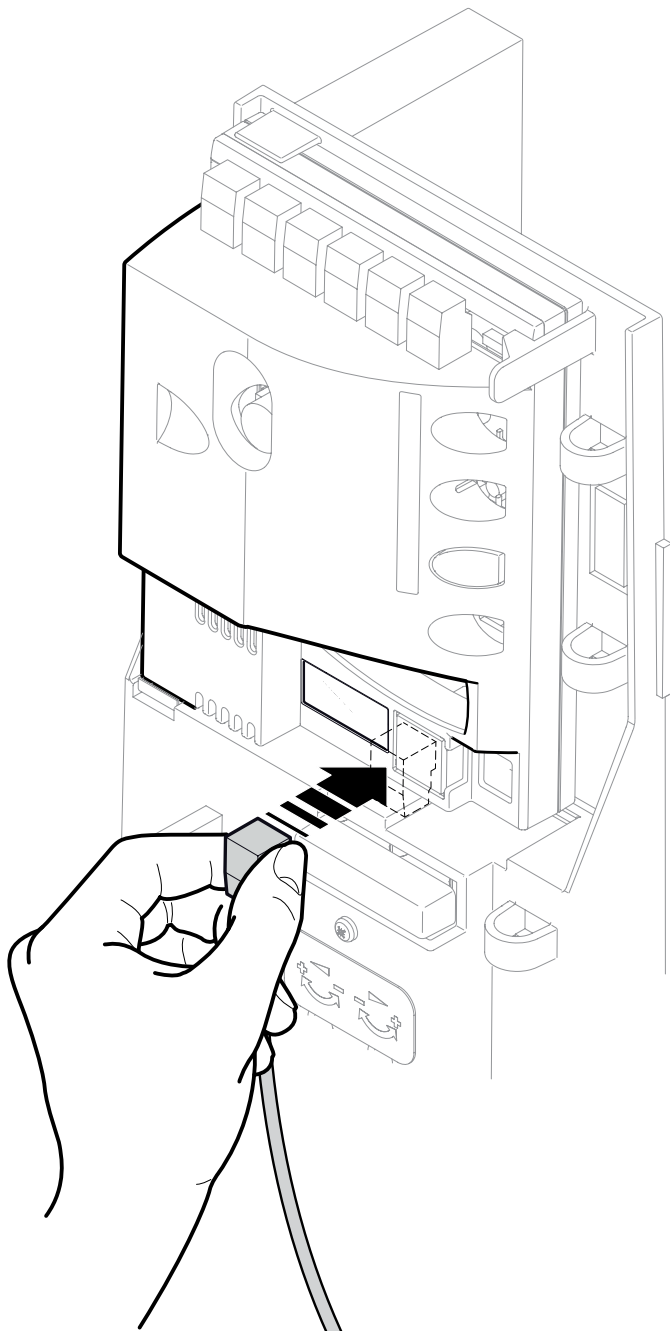

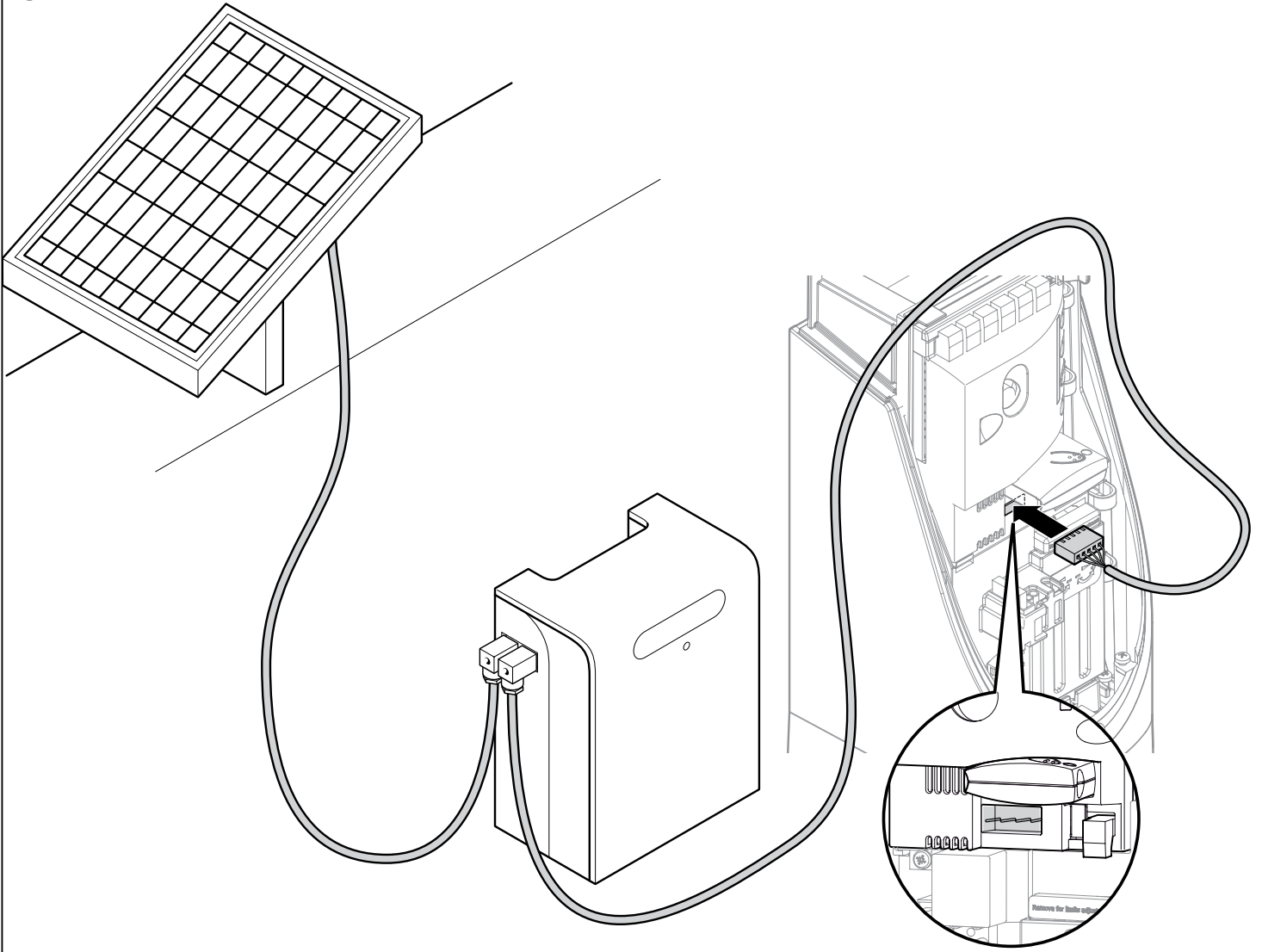

Contents

Chapter 1 - WARNINGS AND GENERAL PRECAUTIONS	
1.1 - Safety warnings	1
1.2 - Warnings about installation	1
1.3 - Warnings about use	2
Chapter 2 - PRODUCT DESCRIPTION AND INTENDED USE	2
Chapter 3 - INSTALLATION	
3.1 - Tests prior to installation	2
3.2 - Operating limits	2
3.2.1 - Product durability	3
3.3 - Works in preparation for installation	3
3.4 - Installation of the gear motor	4
3.5 - Adjusting the mechanical limit switches	4
3.6 - Manually releasing and locking the gear motor	4
Chapter 4 - ELECTRICAL CONNECTIONS	
4.1 - Description of the electrical connections	4
Chapter 5 - INTEGRATED FLASHING LIGHT	5
Chapter 6 - FINAL CHECKS AND START-UP	
6.1 - Selecting the direction	5
6.2 - Connecting to the power supply	5
6.3 - Recognition of the devices	5
6.4 - Recognition of the length of the leaf	5
6.5 - Checking gate movement	6
6.6 - Connecting other devices	6
Chapter 7 - TESTING AND COMMISSIONING	
7.1 - Testing	6
7.2 - Commissioning	6
MAINTENANCE OF THE PRODUCT	6
DISPOSAL OF THE PRODUCT	6
Chapter 8 - PROGRAMMING	
8.1 - Preset functions	7
8.2 - Programming keys	7
8.3 - Programming	7
8.4 - Level 1 programming (ON-OFF functions)	8
8.5 - Level 2 programming (adjustable parameters)	8
Chapter 9 - FURTHER DETAILS	
9.1 - Adding or removing devices	10
9.1.1 - BlueBUS	10
9.1.2 - STOP input	10
9.1.3 - Photocells	10
9.1.4 - FT210B Photo-sensor	11
9.1.5 - Slight in "Slave" mode	11
9.1.6 - Recognition of other devices	11
9.1.7 - Radio receiver	12
9.1.8 - Connection and installation of the buffer battery	12
9.1.9 - Connecting up the Oview programmer	12
9.1.10 - Connecting the Solemyo solar energy system	12
9.2 - Special functions	12
9.2.1 - The "Always open" function	12
9.2.2 - The "Move anyway" function	12
9.2.3 - Maintenance notification	12
9.2.4 - Control of the number of manoeuvres performed	13
9.2.5 - Manoeuvre counter reset	13
Chapter 10 - TROUBLESHOOTING... (troubleshooting guide)	14
10.1 - Troubleshooting	14
10.2 - Malfunctions archive	14
10.3 - Flashing light signalling	14
10.4 - Signals on the control unit	15
TECHNICAL CHARACTERISTICS OF THE PRODUCT	17
Declaration of Conformity	18
Operation Manual (removable appendix)	19
PICTURES	I - VII

1.1 - Safety warnings

- **WARNING! – This manual contains important instructions and warnings regarding safety.** Incorrect installation could lead to serious injury. Before starting, please read all sections of the manual carefully. If in any doubt, suspend installation and call the Nice Support Service for clarification.
- **WARNING! - Important: please retain this manual for future maintenance work and product disposal.**

Particular warnings concerning the suitable use of this product in relation to the 98/37CE "Machine Directive" (2006/42/CE):

- This product comes onto the market as a "machine component" and is therefore manufactured to be integrated to a machine or assembled with other machines in order to create "a machine", under the directive 2006/42/CE, only in combination with other components and in the manner described in the present instructions manual. As specified in the directive 2006/42/CE the use of this product is not admitted until the manufacturer of the machine on which this product is mounted has identified and declared it as conforming to the directive 2006/95/CE.

Particular warnings concerning the suitable use of this product in relation to the 73/23/EEC "Low Voltage" Directive and 2006/95/CE:

- This product responds to the provisions foreseen by the "Low Voltage" Directive if used for the use and in the configurations foreseen in this instructions manual and in combination with the articles present in the Nice S.p.a. product catalogue. If the product is used in unforeseen configurations or with other unforeseen products, the requirements may not be guaranteed; the use of the product is prohibited in these situations until compliance with the specified requirements of the directive have been verified by the installers.

Particular warnings concerning the suitable use of this product in relation to the 2004/108/CE "Electromagnetic Compatibility" Directive:

- This product has been subjected to electromagnetic compatibility tests in the most critical situations of use and in the configurations foreseen in this instructions manual and in combination with the articles present in the Nice S.p.a. product catalogue. If the product is used in unforeseen configurations or with other unforeseen products, the electromagnetic compatibility may not be guaranteed; the use of the product is prohibited in these situations until compliance with the specified requirements of the directive have been verified by the installers.

1.2 - Warnings about installation

- Before commencing the installation, check that this product is suitable for controlling your gate or doorway (see Chapter 3 and the "Product technical specifications"). If it is not suitable, DO NOT continue with the installation.
- **All installation and maintenance work must be carried out with the automation system disconnected from the electricity supply.** If the power disconnection device cannot be seen from where the automation system is positioned, then before starting work a notice must be attached to the disconnection device bearing the words "CAUTION! MAINTENANCE IN PROGRESS".
- Handle the product with care during installation, taking care to avoid crushing, denting or dropping it, or contact with liquids of any kind. Keep the product away from sources of heat and naked flames. Failure to observe the above can damage the product, and increase the risk of danger or malfunction. Should this occur, suspend installation work immediately and contact the Nice Support Service.
- Do not modify any part of the product. Prohibited modifications can only lead to malfunctions. The manufacturer declines all liability for damage caused by arbitrary modifications to the product.
- If the gate being automated has a pedestrian gate, then the system must include a control device that will inhibit the operation of the motor when the pedestrian gate is open.
- Provide a disconnection device (not supplied) in the plant's power supply grid, with a contact opening distance that permits complete disconnection under the conditions dictated by overvoltage category III.
- **WARNING! - Turning on the power supply to the motor before you have completed installation is strictly prohibited.**
- The key selector must be positioned within view of the automation mechanism, far away from its moving parts, at a minimum height of 1.5 m from the ground and in a location which is not accessible to the public. If it is used in "manned" mode, make sure there are no people in the vicinity of the automation mechanism.
- Check that there are no points where people could become trapped or crushed against fixed parts when the gate is fully open or fully closed; if there are, provide protection for these parts.
- The product may not be considered a complete anti-intrusion protection system. If you wish to have effective protection, combine the automation mechanism with other security devices.
- Check whether other devices are necessary to complete the automation mechanism on the basis of the specific circumstances of use and the hazards present; for example, the risk of impact, crushing, cutting, dragging, etc. and all other dangers must be taken into consideration.
- If an automatic switch or a fuse is tripped, identify and eliminate the reason before resetting it.
- The automation mechanism cannot be used before it has been commis-

sioned as specified in the chapter on “Testing and commissioning”.

- Inspect the automation mechanism frequently to check for unbalancing, signs of wear or damage to electrical cables and mechanical parts. Do not use the automation mechanism if adjustment or repair is required.
- If it is not used for a long time, remove the optional battery (PS124) and keep it in a dry place to make sure it does not leak harmful substances.
- The packing materials of the product must be disposed of in compliance with local regulations.

1.3 - Warnings about use

- The product is not intended for use by persons, including children, with limited physical, sensory or mental capacities, or who lack experience or knowledge, unless supervised or trained in the use of the product by a person responsible for their safety.
- Any children near the automation system must be kept under supervision to ensure that they do not play with it.
- Do not allow children to play with the fixed control devices. Keep remote control devices out of their reach as well.
- Clean the surfaces of the product with a soft, slightly damp cloth. Use only water; do not use cleaning products or solvents.

2 PRODUCT DESCRIPTION AND INTENDED USE

This product is intended to be used to automate sliding gates used in residential premises. **WARNING! – All uses other than the intended use described and use in environmental conditions other than those described in this manual should be considered improper and forbidden!**

Slight combines an electronic control centre with a finger joint. Electrical connections with external devices are simplified thanks to use of the “BlueBUS”, a technique permitting connection of multiple devices with only 2 wires.

If powered from the grid, Slight can host a buffer battery (mod. PS124, optional accessory) which permits the automation mechanism to continue to perform a number of manoeuvres even in the event of a black-out. In the event of a black-out, it is still possible to move the gate by releasing the gearmotor using the key provided (see paragraph 3.7); or you may use the optional accessory: the PS124 buffer battery that permits a number of manoeuvres even in the absence of grid power.

The automation mechanism permits installation of various accessories to add functions and improve security.

3 INSTALLATION

3.1 - Tests prior to installation

Caution! - The installation of SLIGHT must be carried out by qualified personnel in compliance with current legislation, standards and regulations, and the directions provided in this manual.

Before proceeding with the installation of SLIGHT you need to make these checks:

- Check that all the materials are in excellent condition, suitable for use and that they conform to the standards currently in force.
- Make sure that the structure of the gate is suitable for automation.
- Make sure that the weight and dimensions of the leaf fall within the specified operating limits provided in chapter “3.2 Operating limits”.
- Check that the force required to start the movement of the leaf is less than half the “maximum torque”, and that the force required to keep the leaf in movement is less than half the “nominal torque”. Compare the resulting values with those specified in Chapter “8 Technical Characteristics”. The manufacturers recommend a 50% margin on the force, as unfavourable climatic conditions may cause an increase in the friction.
- Check that the internal dimensions of the column are appropriate (at least 140 x 140 mm)
- Check the seats prepared for fixing the column
- Check that there is enough space in the area at the back, inside the column to insert the gearmotor and to pass the cables through and connect them.
- Check that the column is correctly earthed in the installation.
- **WARNING!** – Make sure that the column has been prepared correctly in compliance with local legislation and guarantees a protection of at least IP44 when the lid is closed.
- Make sure that there are no points of greater friction in the opening or closing phases of the gate leaves.
- Check that there is no risk of derailment or that the leaves may come off their guides.
- Make sure that the mechanical stops are sturdy enough and that there is no

risk of deformation even if the leaf hits the mechanical stop violently.

- Make sure that the gate section is balanced, i.e. it must not move if left still in any position.
- Make sure that the area where the gearmotor is fixed is not subject to flooding; if necessary, mount the gearmotor raised from the ground.
- Make sure that the installation area enables the release of the gearmotor and that it is safe and easy to release it manually.
- Make sure that the mounting positions of the various devices are protected from impacts and that the mounting surfaces are sufficiently sturdy.
- Components must never be immersed in water or other liquids.
- Keep SLIGHT away from heat sources and open flames; from acid, saline or potentially explosive atmospheres; this could damage SLIGHT and cause malfunctions or dangerous situations.
- If there is an access door in the leaf, or within the range of movement of the gate, make sure that it does not obstruct normal travel and, if necessary, provide an appropriate interblock system.
- Connect the control unit to an electricity supply with a safety earth system.
- Connect the gate to the protective earth in accordance with current legislation.
- Provide a device on the electricity supply line that ensures complete disconnection of the automation mechanism from the grid. The disconnection device must have contacts with an opening distance large enough to permit complete disconnection under the conditions sanctioned by overvoltage category III, in accordance with installation regulations. The device ensures quick, safe disconnection from the power supply if needed, and must therefore be positioned in view of the automation mechanism. If, on the other hand, it is located in a position which is not visible, there must be a system for preventing accidental or unauthorized reconnection with the power grid to prevent this risk. The disconnection device is not supplied with the product.

3.2 - Operating limits

Information on the performance of products in the SLIGHT range are supplied in the chapter on “Technical Characteristics” and this is the only information needed to determine whether the products are suitable for the intended application.

The structural characteristics of SLIGHT make it suitable for use on sliding leaves in conformity with the limits indicated in tables 1 and 2.

The effective suitability SLIGHT to automate a particular sliding gate depends on the friction as well as other correlated factors, such as ice, that could interfere with the movement of the leaf.

For an effective control it is absolutely vital to measure the force necessary to move the leaf throughout its entire run and ensure that this is less than half of the “nominal torque” indicated in chapter 8 “Technical characteristics” (a 50% margin on the force is recommended, as unfavourable climatic conditions may cause an increase in the friction); furthermore, it is necessary to take into consideration the data indicated in tables 1 and 2 to establish the number of cycles/hour, consecutive cycles and maximum speed allowed.

Leaf width (m)	Max. cycles/hour Max. consecutive cycles
Up to 4	35 14
4 ÷ 6	23 11

Leaf weight (kg)	Percentage of cycles Maximum permitted speed
Up to 200	100% V6 = Extremely fast
200 - 400	50% V5 = Very fast

The length of the leaf makes it possible to determine both the maximum number of cycles per hour and consecutive cycles, while the weight makes it possible to determine the reduction percentage of the cycles and the maximum speed allowed. For example if the leaf is 5 m long it will be possible to have 23 cycles/hour and 11 consecutive cycles. However, if the leaf weighs 350 Kg, they must be reduced to 50%, resulting in 11 cycles/hour and 5 consecutive cycles, while the maximum speed allowed is V5: “very fast”. The control unit has a limiting device which prevents the risk of overheating based on the load of the motor and duration of the cycles. This device triggers when the maximum limit is exceeded. The manoeuvre limiting device also measures the ambient temperature reducing the manoeuvre further when the temperature is particularly high.

3.2.1 - Product durability

Durability is the average economic life span of the product. The value of the life span is strongly influenced by the intensity of the manoeuvres, i.e. the sum of all factors that contribute to product wear, see **Table 3**.

To estimate the life span of your automated device, proceed as follows:

01. Add the values of the items in **Table 3** regarding the system conditions;
02. In **Graph 1** from the value obtained above, trace a vertical line until it intersects the curve; from this point trace a horizontal line until it intersects the line of the "manoeuvre cycles". The obtained value is the estimated life span of your product.

The lifetime values specified in the graph are only obtainable if the maintenance schedule is strictly observed (see chapter "Maintenance schedule"). The estimation of durability is made on the basis of design calculations and the results of tests performed on prototypes. As it is only an estimation, it does not represent any form of guarantee on the effective life span of the product.

Example of durability calculation: automation of a gate with a door 4.5 m long with a weight of 250 Kg, installed near the sea:

Table 3 shows the "severity index" for this type of installation: 10% ("Door length"), 15% ("Door weight") and 15% ("Presence of dust, sand or salt").

These indicators must be added together to obtain the overall severity index, which is in this case 40%. With the value identified (40%), look at the horizontal axis of Graph 1 ("severity index"), and identify the value corresponding to the number of "manoeuvre cycles" our product will be able to perform in its life span, about 105,000 cycles.

		Severity index %
Leaf length m	< 3 m	0%
	3 - 4 m	5%
	4 - 5 m	10%
	5 - 6 m	20%
Leaf weight Kg	< 200 kg	0%
	200 - 300 kg	15%
	300 - 400 kg	30%
Surrounding temperature greater than 40°C or lower than 0°C or humidity greater than 80%		20%
Presence of dust, sand and salinity		15%
Set motor power to "level 4"		15%

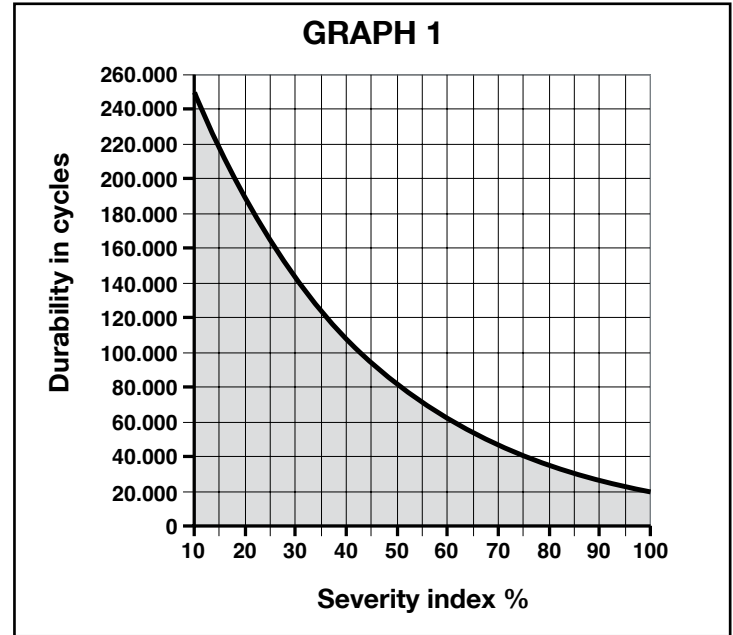

3.3 - Works in preparation for installation

La **fig. 2** provides an example of an automation system, produced using **Nice components**:

- a Key-operated selector switch
- b Photocells on post
- c Photocells
- d Main fixed edge (optional)
- e Main movable edge
- f Rack
- g Secondary fixed edge (optional)
- h Flashing light with incorporated aerial
- i Slight
- l Secondary movable edge (optional)

These parts are positioned according to a typical standard layout. With reference to **fig. 2**, locate the approximate position for installation of each component envisaged in the system. **Important** – Before installation, prepare the electric cables required for the system, with reference to **fig. 2** and to "**Table 4 - Technical specifications of electric cables**".

Caution - When laying the ducting for routing the electrical cables, also take into account that due to possible deposits of water in the routing ducts, the connection pipelines might create condensate in the control unit, with consequent damage to the electronic circuits.

Connection	Cable type	Maximum permitted length
A: Electricity supply line	cable 3 x 1.5 mm ²	30 m (note 1)
B: Flashing light with aerial	No.1 cable 2x0.5mm ²	20m
	No.1 RG58 type of protected cable	20m (recommended less than 5m)
C: Photocells	No.1 cable 2x0.5mm ²	30m (note 2)
D: Key selector	No.2 cables 2x0.5mm ² (note 3)	50m
E: Fixed edges	No.1 cable 2x0.5mm ² (note 4)	30m
F: Movable edges	No.1 cable 2x0.5mm ² (note 4)	30m (note 5)

Note 1 – power supply cable longer than 30 m may be used provided it has a larger gauge, e.g. 3x2.5mm², and that a safety earthing system is provided near the automation unit.

Note 2 – If the "BLUEBUS" cable is longer than 30 m, up to 50 m, a 2x1mm² cable is needed.

Note 3 – A single 4x0.5mm² cable can be used instead of two 2x0.5mm² cables.

Note 4 – if there is more than one edge, please refer to paragraph "9.1.2 STOP input" for the type of recommended connection.

Note 5 – special devices which enable connection even when the leaf is moving must be used to connect movable edges to sliding leaves.

WARNING! – The cables used must be suited to the type of environment of the installation site.

3.5 - Installation of the gear motor

WARNINGS

- **Incorrect installation may cause serious physical injury to those working on or using the system.**
- **Before starting automation assembly, make the preliminary checks as described in paragraphs 3.1 and 3.2.**

If the surface it is to rest on already exists, the gear motor must be mounted directly onto that surface using appropriate means, e.g. expansion bolts. Otherwise, in order to mount the gear motor:

01. Dig an adequately-sized foundation hole, using as a reference the values indicated in **fig. 3**;
02. Prepare one or two tubes for the passage of the electricity cables as in **fig. 4**;
03. Assemble the two anchoring devices onto the foundation plate, placing one nut under and one over the plate; the bolt must be tightened as in **fig. 5** so that the threaded part emerges about 25-35 mm above the plate;
04. Pour in the concrete and before it starts to set, place the foundation plate at the levels indicated in Figure 3; make sure that it is parallel to the leaf and perfectly level, **fig. 6**. Wait for the concrete to set fully;
05. Remove the 2 nuts above the plate;
06. Before proceeding with installation, you should position the door halfway along its travel and then anchor the gear motor to the foundation plate. This ensures that the mechanical limit switches are adjusted automatically (Paragraph 3.6) and then rest the gear motor on it.
07. Make sure that the gear motor is perfectly parallel with the the leaf and then tighten the 2 nuts and washers as shown in **fig. 7**;
08. At this point, if there is already a rack, adjust the mechanical limit switches as described in paragraph 3.6.

If the rack is to be installed, proceed as follows:

a) Release the gear motor as shown in the "Release and manual movement" paragraph in chapter "Instructions and Warnings for users of the Slight gear motor".

b) Position the leaf in a closing position, leaving it at least 50cm from the limit switch stop. Rest the first part of the rack against the pinion and make sure that the start of the rack corresponds to the start of the leaf as in **fig. 9**.

Make sure that there is some play of about 1-2 mm between the pinion and the rack, and then fix the rack to the leaf using appropriate means.

In order to avoid the weight of the leaf bearing on the gear motor, it is important that there is some play of about 1-2 mm between the rack and the pinion as in fig. 10.

c) Slide the leaf and always use the pinion as a reference to fix the other elements of the rack.

d) Cut the last part of the rack for the surplus part.

e) Try to open and close the leaf a number of times and check that the rack moves in line on the pinion with a maximum misalignment of 5 mm and that the play of 1-2 mm between the pinion and the rack is observed throughout the length.

f) Briskly tighten the fixing nuts of the gear motor, making sure that it is firmly fixed to the ground; cover the fixing nuts with the special tops as in Figure 11.

3.6 - Adjusting the mechanical limit switches

01. Release the gear motor with the key provided (refer to paragraph 3.7);
02. Then manually perform a complete Opening and Closing manoeuvre to permit automatic adjustment of the mechanical limit switches. **Important** – During this manoeuvre, check that the rack runs in alignment with the pinion, with a maximum misalignment of 5 mm, and that there is a play of 1-2 mm between pinion and rack along its entire length (**fig. 8**);
03. Lastly, manually position the leaf halfway along its travel and lock the gear motor in place with the key provided (refer to paragraph 3.7).

3.7 - Manually releasing and locking the gear motor

The gear motor is equipped with a mechanical blocking system to enable manual opening and closing of the gate.

These manual operations should only be performed in the event of a power failure, malfunctions or during the installation procedures.

01. Insert the release wrench (**fig. 9**);
02. Rotate the wrench clockwise (90° - **fig. 10**);
03. It is now possible to move the leaf into the desired position manually.

4 ELECTRICAL CONNECTIONS

WARNING! – All electrical connections must be made while disconnected from the grid and disconnected from the buffer battery (if any).

01. Insert all the connecting cables to the various devices, leaving them 20 to 30 cm longer than necessary. Refer to Table 5 for the cable type and Figure 2 for connections.
02. Use a clamp to hold together all the cables that enter the gear motor, and place the clamp underneath the hole through which the cables enter.
03. Connect up the power cable to the terminal provided, as shown in Figure 11, then use a clamp to lock the cable onto the first cable ring.
04. Connect up the other cables according to the diagram in Figures 12 and 13. For greater commodity, the terminal clamps are removable.
05. After making the connections, lock the cables you have collected together in place using the rings provided (**fig. 12**), and anchor the excess part of the aerial cable to the other cables.

To connect up 2 motors on opposite leaves, refer to paragraph "9.1.5 SLIGHT in Slave mode".

4.1 - Description of the electrical connections

- **FLASH** = output for one or two "LUCYB" or similar type flashing lights with single 12V maximum 21W bulb.
- **S.C.A.** = "Open Gate Light" output; a 24V (max. 4W) signal light can be connected. It can also be programmed for other functions; see paragraph "8.4 Level two functions".
- **BLUEBUS** = compatible devices can be connected up to this terminal. They are connected in parallel using two conductors only, through which both the electricity supply and the communication signals travel. For more useful information about BlueBUS see also paragraph "9.1.1 BlueBUS".
- **STOP** = input for the devices which block or that may stop a manoeuvre in progress. Contacts like "Normally Closed", "Normally Open" or constant resistance devices can be connected up using special procedures on the input. For more useful information about STOP see also Paragraph "9.1.2 STOP input".
- **STEP-BY-STEP** = input for devices which control Step-by-Step movement. It is possible to connect contacts of the "Normally Open" type to this input.
- **OPEN** = input for devices which control only the opening movement. It is possible to connect contacts of the "Normally Open" type to this input.
- **CLOSE** = input for devices which control only the closing movement. It is possible to connect contacts of the "Normally Open" type to this input.
- **AERIAL** = connection input for the radio receiver aerial (the aerial is incorporated in LUCY B).

5 INTEGRATED FLASHING LIGHT

Slight has an integrated flashing card which can be connected to the Flash or S.C.A. output on the control unit. In order to program these functions, refer to paragraph "8.5 Level 2 programming".

6 FINAL CHECKS AND START UP

The manufacturers recommend you position the leaf at approximately half travel before starting the checking and start up phase of the automation. This will ensure the leaf is free to move both during opening and closure.

6.1 - Selecting the direction

The direction of the opening manoeuvre must be chosen depending on the position of the gear motor with respect to the leaf. If the leaf must move left for opening, the selector must be moved towards left as shown in the Figure,

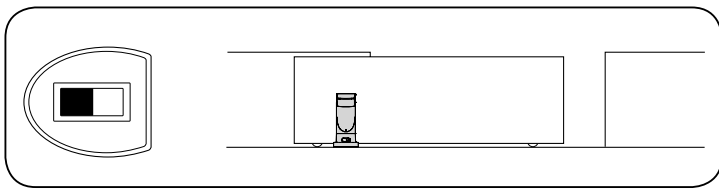

alternatively, if the leaf has to move right during opening, the selector must be moved towards the right as shown in the Figure.

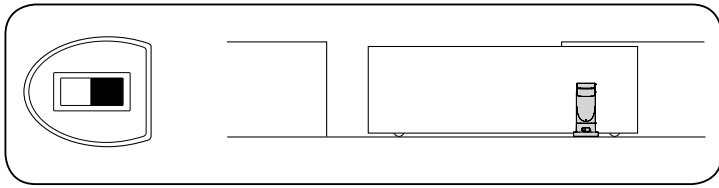

6.2 - Connecting to the power supply

WARNING! – Connecting SLIGHT to the power supply must only be performed by qualified and experienced personnel in possession of the necessary requisites and in full respect of the laws, provisions and standards currently in force.

As soon as SLIGHT is energized, you should check the following:

01. Check that the BlueBUS led flashes regularly at the frequency of one flash per second.
02. Make sure that the LEDs on the photocells flash (both on TX and RX); the type of flashing is not important as it depends on other factors.
03. Make sure that the flashing light connected to the FLASH output and the indicator light connected to the "Open Gate Indicator" output are off.

If the above conditions are not satisfied, you should immediately switch off the power supply to the control unit and check the electrical connections more carefully.

Please refer to chapter "10.1 Troubleshooting" for useful information on searching for and diagnosing failures.

6.3 - Recognition of the devices

After connecting up the power supply, the control unit must be made to recognise the devices connected up to the BLUEBUS and STOP inputs. Before this phase, LEDs L1 and L2 will flash to indicate that recognition of the devices must be carried out.

01. Press and hold keys [▲] and [Set].
02. Release the keys when LEDs L1 and L2 start to flash quickly (after around 3s).
03. Wait a few seconds until the control unit has completed the device recognition procedure.
04. When the recognition stage is completed the STOP LED must remain on, while the L1 and L2 LEDs must go off (LEDs L3 and L4 may start flashing).

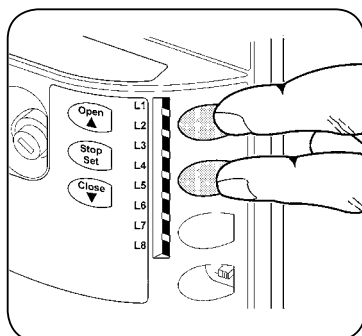

The connected devices recognition stage can be repeated at any time, even after the installation (for example, if an additional device is installed); please see paragraph "9.1.6 Recognition of other devices" in order to perform a new recognition.

6.4 - Recognition of the length of the leaf

After recognizing the devices, L3 and L4 LEDs start flashing; the control unit must recognize the length of the gate. During this stage, the length of the leaf is measured from the closing limit switch to the opening limit switch. This measurement is required to calculate the deceleration points and the partial opening point.

01. Press and hold keys [▲] and [Set].
02. Release the keys when the manoeuvre starts (after approx. 3 s).
03. Check the manoeuvre in progress is an opening manoeuvre. Otherwise, press the [Stop] key and carefully check paragraph "6.1 Selecting the direction"; then repeat the process from point 1.
04. Wait for the control unit to fully open the gate by reaching the opening limit switch; the closing manoeuvre will start immediately afterwards.
05. Wait for the control unit to fully close the gate.

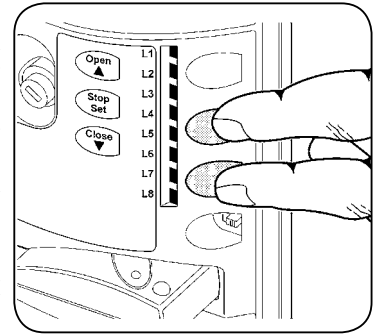

If the above conditions are not satisfied, you should immediately switch off the power supply to the control unit and check the electrical connections more carefully. Other useful information can be found in the chapter "10.1 Troubleshooting".

If it is necessary to adjust limit switch positions more finely, use the 2 adjustment knobs (fig. 14 and 15) in their gear motor, as follows:

01. Press the ▲ or ▼ key on the control unit to open or close the leaf, on the basis of the position to be defined.
02. Remove the cover that blocks the 2 adjustment knobs (fig. 14).
03. Identify the adjustment knob with the arrow indicating the direction of the limit switch to be adjusted and turn it half a turn (equal to about 3 cm of movement of the gate) fig. 15.
04. Next, on the control unit, press key▲ or key ▼ again to open or close the leaf to register the new position. Repeat as necessary until the leaf reaches the desired limit switch.

WARNING! – If it is necessary to define the position of the limit switch with greater precision, move the leaf back a few centimetres by giving the opening or closing commands (▲ or ▼) on the control unit and then send the command in the direction to be checked.

Note – If you have already performed manual adjustment and need to repeat the entire procedure, you can return the limit switches to their initial condition by turning the 2 adjustment knobs toward the "–" sign until the microswitches are tripped (fig. 15). Then repeat the entire limit switch adjustment procedure.

Important – If, at the start of the installation phase, the leaf is not in the correct position midway along its travel when the motor is anchored in place and the pinion is moved along the rack, it may be necessary to reduce the position of the limit switch on one side.

In this case, if the leaf opens until it hits the retainer, without complying with the set position, turn the adjustment knob (identified by an arrow indicating the direction in which the door moves) toward the "–" sign until the limit switch is tripped. After this, oversee adjustment of the unit again and use precision adjustment if necessary.

If necessary, adjust the door length again.

6.5 - Checking gate movements

On completion of the recognition of the length of the leaf, it is advisable to carry out a number of manoeuvres in order to check the gate travels properly.

01. Press the [Open] key to open the gate. Check that gate opening occurs correctly, without any variations in speed. The leaf must only slow down when it is between 70 and 50 cm from the opening limit switch, and stop, as a result of the limit switch, at 2-3 cm from the mechanical opening stop.
02. Press the [Close] key to close the gate. Check that gate opening occurs correctly, without any variations in speed. The leaf must only slow down when it is between 70 and 50 cm from the closing limit switch, and stop, as a result of the limit switch, at 2-3 cm from the mechanical closing stop.
03. During the manoeuvre, check that the flashing light flashes at a speed of 0.5 seconds on and 0.5 seconds off. If present, also check the flashes of the light connected to the S.C.A. terminal: slow flashes during opening, quick flashes during closing.
04. Open and close the gate several times to make sure that there are no points of excessive friction and that there are no defects in the assembly or adjustments.
05. Check that the fastening of the SLIGHT gear motor, the rack and the limit switch brackets are solid, stable and suitably resistant, also when the gate accelerates or decelerates sharply.

6.6 - Connecting other devices

If the user needs to feed external devices such as a proximity reader for transponder cards or the illumination light of the key-operated selector switch, it is possible to tap power as shown in Figure. The power supply voltage is 24Vdc -30% to +50% with a maximum available current of 100mA.

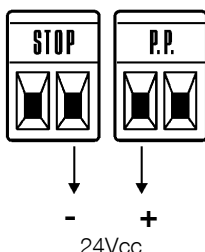

7 TESTING AND COMMISSIONING

This is the most important stage in the automation system installation procedure in order to ensure the maximum safety levels. Testing can also be adopted as a method of periodically checking that all the various devices in the system are functioning correctly.

WARNING! – Testing of the entire system must be performed by qualified and experienced personnel who must establish which tests to conduct on the basis of the risks involved, and verify the compliance of the system with applicable regulations, legislation and standards, in particular with all the provisions of EN standard 12445 which establishes the test methods for automation systems for gates.

7.1 - Testing

Each component of the system, e.g. safety edges, photocells, emergency stop, etc. requires a specific testing phase. We therefore recommend observing the procedures shown in the relative instruction manuals. To test SLIGHT proceed as follows:

01. Ensure that the instructions outlined in this manual and in particular in chapter 1 "WARNINGS" have been observed in full.
02. Release the gear motor as indicated in the paragraph "Manually releasing and locking the gear motor" in the chapter "Instructions and Warnings for users of the SLIGHT gear motor".
03. Make sure you can move the door manually both during opening and closing with a force of max. 390N (40 kg approx.).
04. Lock the gearmotor.
05. Using the control or stop devices (key-operated selector switch, control buttons or radio transmitter) test the opening, closing and stopping of the gate and make sure that the leaves move in the intended direction.
06. Check the proper operation of all the safety devices, one by one (photocells, sensitive edges, emergency stop, etc.) and check that the gate performs as it should. In particular, each time a device is activated the "Blue-BUS" LED on the control unit flashes 2 times quickly, confirming that the control unit recognizes the event.
07. If the dangerous situations caused by the movement of the leaf have been safeguarded by limiting the impact force, the user must measure the impact force according to the EN 12445 standard. If the adjustment of the "speed" and control of the "motor force" are used to assist the system in the reduction of the impact force, try to find the adjustment that gives the best results.

7.2 - Commissioning

Commissioning can take place only after all the testing phases of the SLIGHT and the other devices have been terminated successfully. It is not permissible to execute partial commissioning or to enable use of the system in makeshift conditions.

01. Prepare and store the technical documentation for the automation for at least 10 years. This must include at least: an assembly drawing of the automation, a wiring diagram, an analysis of hazards and solutions adopted, a manufacturer's declaration of conformity of all the devices installed (for SLIGHT use the annexed CE declaration of conformity); a copy of the automation system instruction manual and maintenance schedule.
02. Post a label on the door providing at least the following data: type of automation, name and address of manufacturer (person responsible for the "commissioning"), serial number, year of manufacture and "CE" marking.
03. Post a permanent label or sign near the gate detailing the operations for the release and manual manoeuvre.
04. Prepare the declaration of conformity of the automation system and deliver it to the owner.
05. Prepare the "Installation instructions and warnings" of the automation system and deliver it to the owner.
06. Prepare the maintenance schedule of the automation system and deliver it to the owner; it must provide all instructions regarding the maintenance of the single automation devices.
07. Before commissioning the automation system, inform the owner in writing regarding dangers and hazards that still exist (e.g. in the "Installation instructions and warnings").

MAINTENANCE OF THE PRODUCT

The automation must be subjected to maintenance work on a regular basis, in order to guarantee that it lasts as long as possible; to this end SLIGHT has a manoeuvre counter and maintenance warning system; see paragraph "9.2.3 Maintenance notification".

WARNING! – The maintenance operations must be performed in strict compliance with the safety directions provided in this manual and according to applicable legislation and standards.

For devices other than SLIGHT follow the directions provided in the corresponding maintenance schedules.

01. SLIGHT requires scheduled maintenance work within at least within 6 months or 20,000 manoeuvres (max.) from the previous maintenance.
02. Disconnect all power supplies (including any buffer batteries).
03. Check for any deterioration in automation system components, paying special attention to erosion or oxidation of the structural parts. Replace any parts which are below the required standard.
04. Check the wear and tear on the moving parts: pinion, rack and the leaf components; if necessary replace them.
05. Connect the electric power sources up again, and carry out all the tests and checks described in section "7.1 Testing".

DISPOSAL OF THE PRODUCT

This product is an integral part of the automation system it controls and must be disposed of along with it.

As in the case of installation, likewise at the end of product lifetime the disassembly and scrapping operations must be performed by qualified personnel.

This product is made of various types of material, some of which can be recycled while others must be scrapped. Seek information on the recycling and disposal methods envisaged by the local regulations in your area for this product category.

Caution! – some parts of the product may contain pollutant or hazardous substances which, if disposed of into the environment, may cause serious damage to the environment or physical health.

As indicated by the symbol alongside, disposal of this product with domestic waste is strictly prohibited. Separate the waste into categories for disposal, according to the methods established by current legislation in your area, or return the product to the retailer when purchasing a new version.

Caution! – Local legislation may envisage serious fines in the event of unlawful disposal of this product.

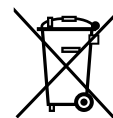

8.1 - Preset functions

The SLIGHT control unit has a number of programmable functions. These functions are pre-set by the manufacturer to a configuration which should satisfy most automations.

8.2 - Programming keys

The SLIGHT control unit features three keys that can be used to command the control unit during tests and programming:

Open	The "OPEN" key enables the user to command the opening of the gate or to move the programming point upwards.
▲	
Stop Set	The "STOP" key enables the user to stop the manoeuvre, if pressed for if pressed for more than 5 seconds, it enables users to enter programming
Close	The "CLOSE" key enables the user to control the closing of the gate or move the programming point downwards
▼	

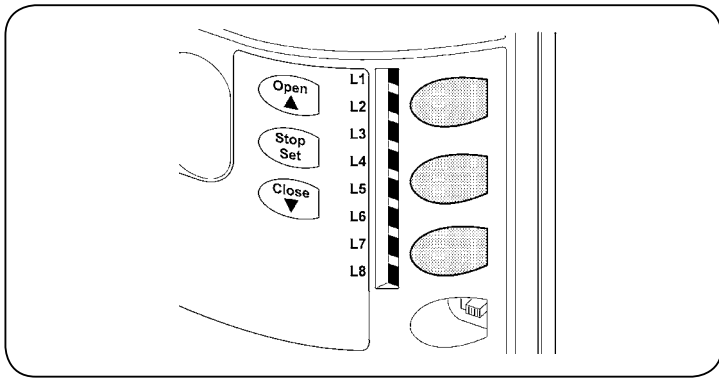

8.3 - Programming

On the SLIGHT control unit, a number of programmable functions are available. The functions are adjusted using 3 keys on the control unit: **▲** **[Set]** **▼** and are used by means of 8 LEDs: **L1...L8**.

The programmable functions on SLIGHT are available on two levels:

Level one: the functions can be adjusted in ON/OFF (active or inactive) modes. In this case, each of the LEDs **L1...L8** indicates one function; if it is lit the function is active, if it is OFF, the function is not active; see Table 5.

Level two: the parameters can be adjusted on a scale of values (from 1 to 8). In this case, each of the LEDs **L1...L8** indicates the set value (there are 8 possible settings). Please refer to Table 7.

TABLE 5 - Level 1 functions (ON-OFF functions)

Led	Function	Description
L1	Automatic Closing	This function causes the door to close automatically after the programmed time has lapsed. The factory set Pause Time is 30 seconds, but can be changed to 5, 15, 30, 45, 60, 80, 120 or 180 seconds. If the function is inactive, functioning will be "semi-automatic".
L2	Close After Photo	This function enables the gate to be kept open for the necessary transit time only. In fact the "Photo" always causes an automatic closure with a pause time of 5s (regardless of the programmed value). The action changes depending on whether the "Automatic closing" function is active or not. When "Automatic Closing" is inactive : The gate always arrives to the totally open position (even if the Photo disengages first). On release of Photo, automatic closure is activated with a pause of 5s. When "Automatic Closing" is active : the opening manoeuvre stops immediately after the photocells have disengaged. After 5 seconds, the gate will begin to close automatically. The "Close after photo" function is always disabled in manoeuvres interrupted by a Stop command. If the "Close after photo" function is inactive the pause time is that which has been programmed or there is no automatic closing if the function is inactive.
L3	Always Close	The "Always Close" function will trigger, and the gate will close if an open gate is detected when the power supply returns. For safety reasons, the manoeuvre is preceded by 5s of flashing. If the function is inactive when the power supply returns, the gate will remain still.
L4	Stand by	It is particularly useful in cases when the buffer battery is being used. If this function is active, the control unit will switch the BLUEBUS output (and consequently the devices) and all the LEDs off one minute after the end of the manoeuvre. The only LED which will remain on is the BLUEBUS LED which will simply flash more slowly. When a command arrives, the control unit will reset to complete functioning. If this function is inactive, there will be no reduction in the consumption.
L5	Peak	If this function is activated, the gradual acceleration at the beginning of each manoeuvre will be disconnected. It enables the peak thrust and is useful whenever static friction is high, e.g. if snow or ice are blocking the leaf. If the thrust is inactive, the manoeuvre will start with a gradual acceleration.
L6	Pre-flashing	With the pre-flashing function, a 3 second pause is added between the flashing light switching on and the beginning of the manoeuvre in order to warn the user, in advance, of a potentially dangerous situation. If pre-flashing is inactive, the flashing light will switch on when the manoeuvre starts.
L7	"Close" becomes "Open partially"	By activating this function all "close" commands ("CLOSE" input or radio command "close") activate a partial opening manoeuvre (see LED L6 on table 7).
L8	"Slave" mode	By activating this function SLIGHT becomes "Slave": in this way it is possible to synchronise the functioning of two motors on opposite leaves where one motor functions as Master and the other as Slave; for further information see "9.1.5 SLIGHT in "Slave" mode".





During the normal functioning of SLIGHT the LEDs **L1...L8** will either be on or off depending on the state of the function they represent. For example **L1** will be on if "Automatic Closing" is active.

8.4 - Level 1 programming (ON-OFF functions)

By default, level 1 functions are all set to OFF, but can be modified at any time as described in Table 6. Take care during modification procedures, as there is a

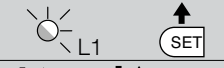
maximum time interval of 10 seconds between pressing one key and another; otherwise the system exits the procedure automatically memorising the changes made up to that time.

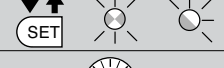
TABLE 6 - Changing ON-OFF Functions

01. Press and hold the “Set” key for about 3 seconds;	
02. Release the “Set” key when the “L1” LED start to flash;	
03. Press keys “▲” or “▼” to move the flashing LED onto the LED representing the function which is to be changed;	
04. Press the “Set” key to change the status of the function: (short flashing = OFF; long flashing = ON);	
05. Wait 10s to exit the programming mode automatically after the maximum time interval.	
Note – Points 3 and 4 can be repeated during the same programming phases in order to set other functions to ON or OFF.	

8.5 - Level 2 programming (adjustable parameters)

The adjustable parameters are factory set as shown in the Table 7 with: “ ” but can be modified at any time as shown in Table 8. Take care during modifi-

cation procedures, as there is a maximum time interval of 10 seconds between pressing one key and another; otherwise the system exits the procedure automatically memorising the changes made up to that time.

TABLE 7 - Level 2 functions (adjustable parameters)

Input LED	Parameter	LED (level)	Value	Description
L1	Pause Time	L1	5 seconds	Adjusts the pause time, namely the time which lapses before automatic closure. Is effective only if automatic closure is enabled.
		L2	15 seconds	
		L3	30 seconds	
		L4	45 seconds	
		L5	60 seconds	
		L6	80 seconds	
		L7	120 seconds	
		L8	180 seconds	
L2	Function STEP BY STEP	L1	Open – stop – close – stop	Manages the sequence of controls associated to the Step-by-Step input or to the 1st radio command.
		L2	Open – stop – close – open	
		L3	Open – close – open – close	
		L4	Apartment block	
		L5	Apartment block 2 (more than 2” generates stop)	
		L6	Step-by-Step 2 (less than 2” causes partial opening)	
		L7	Hold-to-run	
		L8	“Semi-automatic” opening, “Man present “ closing	
L3	Speed of motor	L1	Very slow	Adjusts the speed of the motor during normal travel.
		L2	Slow	
		L3	Medium	
		L4	Fast	
		L5	Very fast	
		L6	Extremely Fast	
		L7	Opens “Fast”; closes “slow”	
		L8	Opens “Extremely Fast” Closes “Fast”	
L4	Output S.C.A.	L1	Open Gate Indicator Function	Adjusts the function associated with S.C.A. output. (whatever the associated function may be, the output supplies a voltage of 24V –30 +50% with a maximum power of 4W when active).
		L2	On if leaf closed	
		L3	On if leaf open	
		L4	Active with 2nd radio output	
		L5	Active with 3rd radio output	
		L6	Active with 4th radio output	
		L7	Maintenance indicator	
		L8	Electric lock	
L5	Force of motor	L1	Super light gate	Adjusts the system which controls the motor force in order to adapt it to the weight of the gate. The force control system also measures the ambient temperature, automatically increasing the force in the event of particularly low temperatures.
		L2	“Very light” gate	
		L3	“Light” gate	
		L4	“Average” gate	
		L5	“Averageheavy” gate	
		L6	“Heavy” gate	
		L7	“Very heavy” gate	
		L8	“Super heavy” gate	







L6	Open Partially	L1	0.5 mt	Adjusts the measurement of the partial opening. Partial opening can be controlled with the 2nd radio command or with "CLOSE", if the "Close" function is present, this becomes "Open partially".
		L2	1 mt	
		L3	1.5 mt	
		L4	2 mt	
		L5	2.5 mt	
		L6	3 mt	
		L7	3.4 mt	
		L8	4 mt	
L7	Maintenance warning	L1	Automatic (depending on the severity of the manoeuvre)	Adjusts the number of manoeuvres after which it signals the maintenance request of the automation (see paragraph "Maintenance notification").
		L2	1000	
		L3	2000	
		L4	4000	
		L5	7000	
		L6	10000	
		L7	15000	
		L8	20000	
L8	List of malfunctions	L1	Result of 1st manoeuvre (most recent)	The type of defect that has occurred in the last 8 manoeuvres can be established (see paragraph "10.2 Malfunctions archive").
		L2	Result of 2nd manoeuvre	
		L3	Result of 3rd manoeuvre	
		L4	Result of 4th manoeuvre	
		L5	Result of 5th manoeuvre	
		L6	Result of 6th manoeuvre	
		L7	Result of 7th manoeuvre	
		L8	Result of 8th manoeuvre	

Note: " " represents factory settings

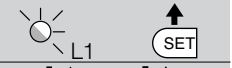
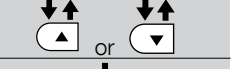
All the parameters can be adjusted as required without any contraindication; only the adjustment of the "motor force" could require special care:

- Do not use high force values to compensate for points of abnormal friction on the leaf. Excessive force can compromise the operation of the safety system or damage the leaf.
- If the "Motor force control" is used in support of the system for impact force reduction, the force measurement procedure must be performed after each adjustment, as envisaged by standard EN 12445.
- Wear and weather conditions may affect the movement of the gate, therefore periodic force readjustments may be necessary.

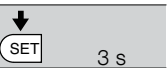
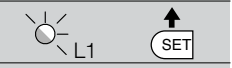

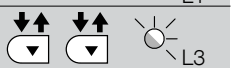

TABLE 8 - To change the adjustable parameters

01. Press and hold the "Set" key for about 3 seconds;	
02. Release the key when the "L1" LED starts flashing;	
03. Press the keys "▲" or "▼" to move the flashing LED onto the input LED representing the parameter which is to be changed;	
04. Press and hold the "Set" key; the "Set" key must be kept pressed during steps 5 and 6;	
05. Wait approx. 3 seconds, after which the LED representing the current level of the parameter which is to be modified will light up;	
06. Press the key "▲" or "▼" to move the LED representing the parameter value;	
07. Release the "Set" key;	
08. Wait 10 seconds (max.) to leave programming.	

Note – Points 3 to 7 can be repeated during the same programming phase in order to set other parameters

Examples of programming: Level 1 and level 2

Level one: the sequence to follow in order to change the factory settings of the functions for activating "Automatic Closing" (L1) and "Always close" (L3) have been included as examples.

01. Press and hold the "Set" key for about 3 seconds;	
02. Release the key when the L1 LED starts flashing;	
03. Press the Set key once to change the status of the function associated with L1 (Automatic closing). LED L1 will now flash with long flashes;	
04. Press the ▼ key twice to move to L3;	
05. Press the Set key to change the status of function associated with L3 (Always close). LED L3 will now flash with long flashes;	
06. Wait 10 seconds (max.) to leave programming.	

Important – Once these operations have been completed, to indicate that the "Automatic Closing" and the "Always Close" functions are active the L1 and L3 LEDs must remain on.

Level two: The sequence to follow in order to change the factory settings of the parameters increasing the “Pause Time” to 60 seconds (input on L1 and level on L5) and reducing the “Motor Force” for light gates (input on L5 and level on L2) have been included as examples:

01. Press and hold the “Set” key for about 3 seconds;



02. Release the key when the L1 LED starts flashing;

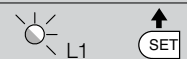

03. Press and hold the “Set” key; the “Set” key must be kept pressed during steps 5 and 6;



04. Wait approx. 3 seconds until LED L3, representing the current level of the “Pause Time”, lights up;

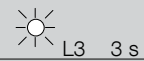

05. Press the ▼ key twice to move the LED which is lit to LED L5 which represents the new “Pause Time” value;



06. Release the “Set” key;



07. Press the ▼ key 4 times to move the flashing LED to LED L5;



08. Press and hold the “Set” key; the “Set” key must be kept pressed during steps 9 and 10;



09. Wait approx. 3 seconds until LED L5, representing the current level of the “Motor Force”, lights up;



10. Press the ▲ key 3 times to move the LED which is lit to L2 which represents the new “Motor Force” value;



11. Release the “Set” key;



12. Wait 10s to exit the programming mode automatically after the maximum time interval.



9 FURTHER DETAILS

9.1 - Adding or removing devices

Devices can be added to or removed from the SLIGHT automation system at any time. In particular, various device types can be connected to “BlueBUS” and “STOP” input as explained in the following paragraphs.

After you have added or removed any devices, the automation system must go through the recognition process again according to the directions contained in paragraph “9.1.6 Recognition of other devices”.

9.1.1 - BlueBUS

BlueBUS technology allows you to connect compatible devices using only two wires which carry both the power supply and the communication signals. All the devices are connected in parallel on the 2 wires of the BlueBUS itself. It is not necessary to observe any polarity; each device is individually recognized because a univocal address is assigned to it during the installation. Photocells, safety devices, control keys, signalling lights etc. can be connected to BlueBUS. The SLIGHT control unit recognizes all the connected devices individually through a suitable recognition process, and can detect all the possible abnormalities with absolute precision. For this reason, each time a device connected to BlueBUS is added or removed the control unit must go through the recognition process; see paragraph “9.1.6 Recognition of Other Devices”.

9.1.2 - STOP input

STOP is the input that stops movement immediately, followed by a brief reverse of the manoeuvre. Devices with contact types Normally Open (NO), Normally Closed (NC) or devices with a constant resistance of 8.2KΩ, such as safety edges can be connected to this input.

During the recognition stage the control unit, like BlueBUS, recognizes the type of device connected to the STOP input (see paragraph “9.1.6 Recognition of Other Devices”); subsequently it commands a STOP whenever a change occurs in the recognized status.

Multiple devices, even of different type, can be connected to the STOP input if suitable arrangements are made.

- Any number of NO devices can be connected to each other in parallel.
- Any number of NC devices can be connected to each other in series.
- Two devices with constant 8.2KΩ constant resistance output can be connected in parallel; if needed, multiple devices must be connected “in cascade” with a single 8.2KΩ terminal resistance.

- It is possible to combine Normally Open and Normally Closed by making 2 contacts in parallel with the warning to place an 8.2KΩ resistance in series with the Normally Closed contact (this also makes it possible to combine 3 devices: Normally Open, Normally Closed and 8.2KΩ).

IMPORTANT – If the STOP input is used to connect devices with safety functions, only the devices with 8.2KΩ constant resistance output guarantee the fail-safe category 3 according to EN standard 954-1.

9.1.3 - Photocells

By means of addressing using special jumpers, the “BlueBUS” system enables the user to make the control unit recognise the photocells and assign them with a correct detection function. The addressing operation must be done both on TX and RX (setting the jumpers in the same way) making sure there are no other couples of photocells with the same address.

TABLE 9 - PHOTOCELL ADDRESSES

Photocell	Jumpers
FOTO External photocell h = 50 activated when gate closes	
FOTO II External photocell h = 100 activated when gate closes	
FOTO 1 Internal photocell h = 50 activated when gate closes	
FOTO 1 II Internal photocell h = 100 activated when gate closes	
FOTO 2 External photocell activated when gate opens	
FOTO 2 II Internal photocell activated when gate opens	
FOTO 3 Single photocell for the entire automation system	

IMPORTANT in the case of the installation of FOTO 3 and FOTO II together the position of the photocell elements (TX-RX) must comply with the provisions contained in the photocell instruction manual.

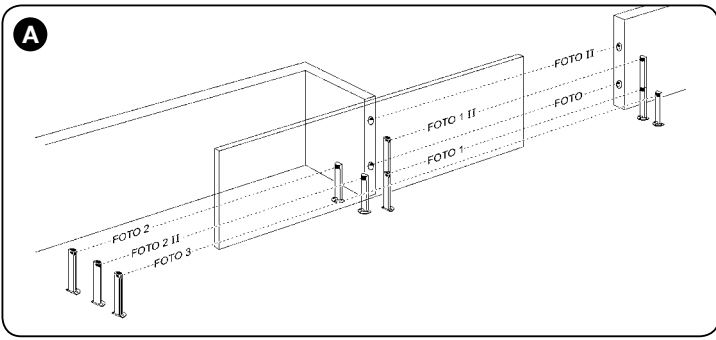

In an automation mechanism for sliding gates with SLIGHT you may install photo-cells as shown in Table 9 and Fig. A. Each time a photocell is added or removed the control unit must go through the recognition process; see paragraph “9.1.6 Recognition of Other Devices”.

9.1.4 - FT210B Photo-sensor

The FT210B photo-sensor unites in a single device a force limiting device (type C in accordance with the EN1245 standard) and a presence detector which detects the presence of obstacles on an optical axis between the TX transmitter and the RX receiver (type D in accordance with the EN12453 standard). The sensitive edge status signals on the FT210B photosensor are transmitted by means of the photocell beam, integrating the two systems in a single device. The transmitting part is positioned on the mobile leaf and is powered by a battery thereby eliminating unsightly connection systems; the consumption of the battery is reduced by special circuits guaranteeing a duration of up to 15 years (see the estimation details in the product instructions). By combining a FT210B device to a sensitive edge (TCB65 for example) the level of security of the “main edge”, required by the EN12453 standard for all “types of use” and “types of activation”, can be attained.

Photosensor FT210B combined with “resistive” sensitive edges (8.2 KOhm), is safe with single faults (class 3 per EN 954-1). It is equipped with a special anti-collision circuit to prevent interference with other detectors, even not synchronised, and enables the addition of other photocells; for example in the case of transit of heavy vehicles where a second photocell is normally positioned at 1 m from the ground. See the FT210B instructions manual for further information concerning connection and addressing methods.

9.1.5 - SLIGHT in “Slave” mode

Properly programming and connecting, SLIGHT can function in “Slave” mode; this type of function is used when 2 opposite gates need to be automated with the synchronised movement of the two leaves. In this mode SLIGHT works as

Master commanding the movement, while the second SLIGHT acts as Slave, following the commands transmitted by the Master (all SLIGHT are Masters when leaving the factory). To configure SLIGHT as a Slave the level one “Slave mode” must be activated (see Table 5).

The connection between SLIGHT Master and SLIGHT Slave is made via BlueBUS. **ATTENTION – In this case the polarity of the connections between the two SLIGHT must be respected as illustrated in fig. 16 (the other devices remain with no polarity).**

- To install 2 SLIGHT in the Master e Slave modes, you must follow these operations:
- Install the 2 motors as indicated in the Figure. It is not important which motor is to function as Slave or Master; when choosing, one must consider the convenience of the connections and the fact that the Step-by-Step command of the Slave only allows the Slave leaf to be opened fully.
 - Connect the 2 motors as shown in fig. 16.
 - Select the opening direction of the 2 motors as shown in the Figure (see also paragraph “6.1 Selecting the direction”).
 - Supply power to the 2 motors.

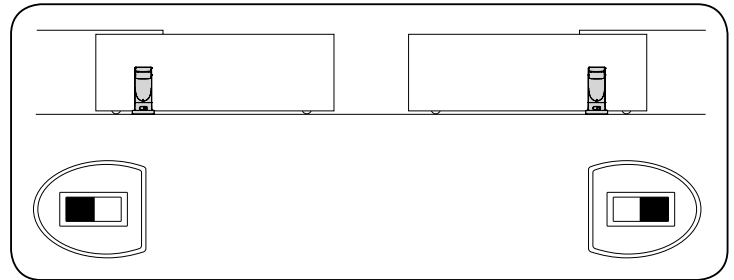

- Programme the “Slave Mode” on the SLIGHT Slave (see Table 5).
- Perform the device recognition on the SLIGHT Slave (see paragraph “9.1.6 Recognition of the devices”).
- Perform the device recognition on the SLIGHT Master (see paragraph “9.1.6 Recognition of the devices”).
- Perform the recognition of the leaf length on the SLIGHT Master (see paragraph “6.4 Recognition of the length of the leaf”).

When connecting 2 SLIGHT in the Master-Slave mode, pay attention that:

- All devices must be connected to the SLIGHT Master (as in Fig. 16) including the radio receiver
- When using buffer batteries, each motor must have its own battery.

All programming performed on SLIGHT Slave are ignored (those on SLIGHT Master override the others) except for those mentioned in Table 10.

TABLE 10 - Programming on SLIGHT Slave independently from SLIGHT Master

Level 1 functions (ON – OFF functions)	Level 2 functions (adjustable parameters)
Stand-by	Motor speed
Peak	SCA Output
Slave mode	Motor Force
Error list	

- On Slave it is possible to connect:
- A flashing light (Flash)
 - An open gate light (S.C.A.)
 - A sensitive edge (Stop)

- A command device (Step by Step) that controls the complete opening of the Slave leaf only
- The Open and Close inputs are not used on the Slave

9.1.6 - Recognition of Other Devices

Normally the recognition of the devices connected to the BlueBUS and the STOP input takes place during the installation stage. However, if new devices are added or

old ones removed, the recognition process can be gone through again by proceeding as shown in Table 11.

TABLE 11 - Recognition of Other Devices

01. Press and hold “▲” and “Set” keys;	
02. Release the keys when the “L1” and “L2” LEDs start to flash quickly (after around 3s);	
03. Wait a few seconds until the control unit has completed the device recognition procedure.	
04. At the end of the recognition the L1 and L2 LEDs will stop flashing, the STOP LED must stay on, while the L1...L8 LEDs will come on based on the status of the ON-OFF functions they represent.	

IMPORTANT – After you have added or removed any devices, the automation system must be tested again according to the directions contained in paragraph “7.1 Testing”.

9.1.7 - Radio receiver

The "SM" radio receiver connector for SMXI or SMXIS type optional radio receivers has been provided in order to enable the user to control SLIGHT, from a distance.

For further information consult the radio receiver instructions manual. To insert the radio receiver, follow the operations indicated in Figure 17. In Table 12 there is a description of the association between the radio receiver output and the command that SLIGHT will perform:

TABLE 12 - commands with transmitter

Output No. 1	Step-by-Step command (STEP-BY-STEP)
Output No. 2	"Partial opening" command
Output No. 3	"Open" command
Output No. 4	"Close" command

9.1.8 - Connection and installation of the buffer battery

WARNING! – Electrical connection of the battery to the unit must be performed exclusively after completing all stages in installation and programming, as the battery is an emergency power supply.

To install and connect up the battery, follow the stages shown in Fig. 18.

9.1.9 - Connecting up the Oview programmer.

The unit has a BusT4 connector for connection of the Oview programming unit permitting complete, rapid management of installation, maintenance and diagnosis of the entire automation mechanism. To access the connector, proceed as shown in Fig. 20 and connect up the connector in the housing provided. The Oview may be connected to multiple units simultaneously (up to 5 with no particular precautions, up to 60 with the warnings stated) and may be left connected up to the unit during regular operation of the automation mechanism. In this case, it may be used to send commands directly to the unit using the "user" menu. You may also update Firmware. If the unit has a radio receiver in the OXI family, you may use Oview to access the transmitter parameters memorized in the receiver.

For more information refer to the instruction manual and the "Opera system book" manual.

9.1.10 - Connecting the Solemyo solar energy system

WARNING! – When the automation mechanism is powered by the "Solemyo" system IT MUST NOT BE POWERED by the electricity grid at the same time.

Refer to the instruction manual provided with the Solemyo system for more information.

To connect up the Solemyo system, proceed as shown in fig. 21.

9.2 - Special functions

9.2.1 - "Always open" function

The "Always open" function is a control unit feature which enables the user to control an opening manoeuvre when the "Step-by-Step" command lasts longer than 2 seconds. This is useful for connecting a timer contact to the "Step-by-Step" terminal in order to keep the gate open for a certain length of time, for example. This feature is valid with any kind of "Step-by-Step" input programming, except for "Close". Please refer to the "Step-by-Step Function" parameter in Table 7.

9.2.2 - Funzione "Muovi comunque"

In the event that one of the safety devices is not functioning properly or is out of use, it is still possible to command and move the gate in "Man present" mode.

Please refer to the Paragraph "Control with safety devices out of order" in the enclosure "Instructions and Warnings for users of the SLIGHT gearmotor" for further information.

9.2.3 - Maintenance notification

With SLIGHT the user is warned when the automation requires a maintenance control. The number of manoeuvres after the warning can be selected from 8 levels, by means of the "Maintenance warning" adjustable parameter (see table 7).

Adjustment level 1 is "automatic" and takes into consideration the severity of the manoeuvre, this being the force and duration of the manoeuvre, while the other adjustments are established based on the number of manoeuvres.

The maintenance request signal is given by means of the flashing light (Flash) or by the light connected to the S.C.A. output when programmed as a "Maintenance light" (see table 9).







The flashing light "Flash" and the maintenance light give the signals indicated in table 13, based on the number of manoeuvres performed in respect to the limits that have been programmed.

TABLE 13 - Maintenance warning with Flash and maintenance light

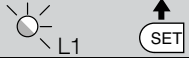
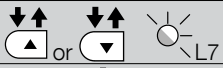
Number of manoeuvres	Flash signal	Maintenance light signal
Lower than 80% of the limit	Normal (0.5s on, 0.5s off)	On for 2s when opening begins
Between 81% and 100% of the limit	Remains ON for 2s at the start of the manoeuvre then carries on normally	Flashes throughout the manoeuvre
Over 100% of the limit	Remains ON for 2s at the start and end of the manoeuvre then carries on normally	Always flashes





9.2.4 - Control of the number of manoeuvres performed

The number of manoeuvres performed as a percentage on the set limit can be verified by means of the "Maintenance warning" function. Follow the indications in Table 14 for this control.

01. Press and hold the "Set" key for about 3 seconds;	
02. Release the "Set" key when the "L1" LED start to flash;	
03. Press the "▲" or "▼" key to move the flashing LED onto L7, i.e. the "input LED" for the parameter "Maintenance notification";	
04. Press and hold the "Set" key; the [Set] key must be kept pressed in continuation during steps 5, 6 and 7;	
05. Wait approx. 3s after which the led associated with the current level of the parameter "Maintenance notification" will light up;	
06. Press and immediately release the "▲" and "▼" keys;	
07. The led corresponding to the selected level flashes a few times. The number of flashes indicates the percentage of manoeuvres performed (in multiples of 10%) with respect to the set limit. For example: with the maintenance warning set on L6 being 10000, 10% is equal to 1000 manoeuvres; if the LED flashes 4 times, this means that 40% of the manoeuvres have been reached (being between 4000 and 4999 manoeuvres). The LED will not flash if 10% of the manoeuvres hasn't been reached;	
08. Release the "Set" key.	

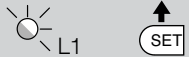
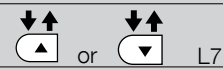
9.2.5 - Manoeuvre counter reset

After the maintenance of the system has been performed the manoeuvre counter must be reset. Follow the instructions in Table 15 for this control.

01. Press and hold the "Set" key for about 3 seconds;	
02. Release the "Set" key when the "L1" LED start to flash;	
03. Press the "▲" or "▼" key to move the flashing LED onto L7, i.e. the "input LED" for the parameter "Maintenance notification";	
04. Press and hold the "Set" key; the "Set" key must be kept pressed during steps 5 and 6;	
05. Wait approx. 3s after which the led associated with the current level of the parameter "Maintenance notification" will light up;	
06. Press and hold keys "▲" and "▼" for at least 5 seconds, then release them. The LED that corresponds to the selected level flashes rapidly indicating that the; manoeuvre counter has been reset;	
07. Release the "Set" key.	

10 WHAT TO DO IF... (troubleshooting guide)

10.1 - Troubleshooting

Table 16 contains instructions to help you solve malfunctions or errors that may occur during the installation stage or in case of failure.

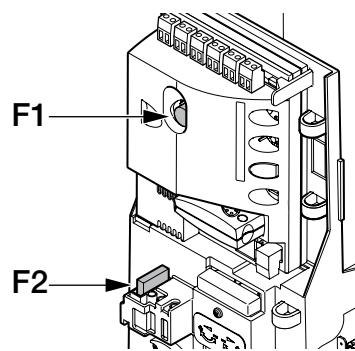

TABLE 16 - Troubleshooting	
Symptoms	Recommended check
The radio transmitter does not control the gate and the LED on the transmitter does not light up	Check to see if the transmitter batteries are exhausted, if necessary replace them
The radio transmitter does not control the gate but the LED on the transmitter lights up	Check to see if the transmitter has been memorised correctly in the radio receiver
No manoeuvre starts and the "BlueBUS" LED does not flash	Check that SLIGHT is powered by a 230V mains supply. Check to see if the fuses F1 and F2 are blown; if necessary, identify the reason for the failure and then replace the fuses with others having the same current rating and characteristics.
No manoeuvre starts and the flashing light is off	Make sure that the command is actually received. If the command reaches the STEP-BY-STEP input, the corresponding "STEP-BY-STEP" LED must light up; if you are using the radio transmitter, the "BlueBus" LED must make two quick flashes.
No manoeuvre starts and the flashing light flashes a few times	Count the flashes and check the corresponding value in table 18
The manoeuvre starts but it is immediately followed by a reverse run	The selected force could be too low for this type of gate. Check to see whether there are any obstacles; if necessary increase the force
The manoeuvre is carried out but the flashing light does not work	Make sure that there is voltage on the flashing light's FLASH terminal during the manoeuvre (being intermittent, the voltage value is not important: approximately 10-30Vdc); if there is voltage, the problem is due to the lamp; in this case replace the lamp with one having the same characteristics; if there is no voltage, there may have been an overload on the FLASH output. Check that the cable has not short-circuited.
The manoeuvre is carried out but the Open Gate Indicator does not work	Check the type of function programmed for the S.C.A. output (Table 7) When the light should be on, check there is voltage on the S.C.A. terminal (approximately 24Vdc). If there is voltage, then the problem will have been caused by the light, which will have to be replaced with one with the same characteristics. If there is no voltage, there may have been an overload on the S.C.A. output. Check that the cable has not short-circuited.

10.2 - Malfunctions archive

SLIGHT can display any faults that have occurred in the last 8 manoeuvres, for example interruption of a manoeuvre due to activation of a photocell or sensitive edge. To check the list of faults, proceed as for Table 17:

TABELLA 17 - Malfunctions archive	
01. Press and hold the "Set" key for about 3 seconds;	3 s
02. Release the key when the "L1" LED starts flashing;	L1
03. Press key "▲" or "▼" to move the flashing LED onto L8, i.e. the "input LED" for the "malfunctions list" parameter;	L8
04. Press and hold the "Set" key; the "Set" key must be kept pressed during steps 5 and 6;	SET
05. Wait approx. 3s after which the leds corresponding to the manoeuvres subject to faults will light up. The L1 LED indicates the result of the last manoeuvre and L8 indicates the result of the 8th manoeuvre. If the LED is on, this means that a defect occurred during that manoeuvre; if the LED is off, this means that no defect occurred during that manoeuvre;	3 s
06. Press keys "▲" and "▼" to select the required manoeuvre: the corresponding LED flashes the same number of times as those made by the flashing light after a defect (see table 18);	and
07. Release the "Set" key.	SET

10.3 - Flashing light signalling

During the manoeuvre the flashing light FLASH flashes once every second. When something is wrong the flashes are more frequent; the light flashes twice with a second's pause between flashes.

TABLE 18 - FLASH Flashing light signalling

Fast flashing	Cause	ACTION
1 flash 1 second's pause 1 flash	Bluebus error	At the starting of the manoeuvre, the devices connected to BLUEBUS do not correspond to those recognized during the recognition phase. One or more devices may be faulty; check and, if necessary, replace them; in case of modifications repeat the recognition process.
2 flashes 1 second pause 2 flashes	Triggering of a photocell	At the starting of the manoeuvre, one or more photocells do not enable it; check to see if there are any obstacles. This is normal when there is an obstacle impeding the movement.
3 flashes 1 second pause 3 flashes	Activation of the "motor force" limiting device	During the movement, the gate experienced excessive friction; identify the cause.
4 flashes 1 second pause 4 flashes	Activation of the STOP input	At the start of or during the manoeuvre, the STOP input was activated; identify the cause.
5 flashes 1 second pause 5 flashes	Error in the internal parameters of the electronic control unit	Wait at least 30 seconds, then try giving a command. if the condition persists it means there is a malfunction and the electronic board has to be replaced.
6 flashes 1 second pause 6 flashes	The maximum manoeuvre limit/hour has been exceeded	Wait for a few minutes until the manoeuvre limiting device drops to under the maximum limit.
7 flashes 1 second pause 7 flashes	There is an error in the internal electric circuits	Disconnect all the power circuits for a few seconds and then try to give the command again. if the condition persists it means there is a serious malfunction and the electronic board has to be replaced
8 flashes 1 second pause 8 flashes	A command that does not permit other commands to be performed is already present.	Check the type of command that is always present; for example, it could be a command from a timer on the "open" input.
9 flashes 1 second pause 9 flashes	The automation mechanism has been stopped by a "Stop automation mechanism" command	Release the automation mechanism by giving the "Release automation mechanism" command

10.4 - Signals on the control unit

The SLIGHT unit has a series of LEDs, each of which can give particular signals both during regular operation and when there is a problem. Refer to table 19, table 20 and the figure shown here.

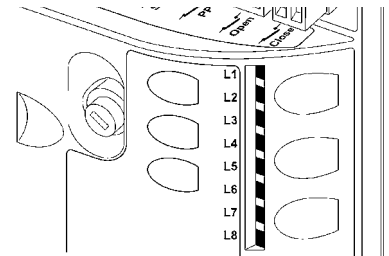

TABLE 19 - Terminal LEDs on control unit

Bluebus LED	Cause	Solution
OFF	Malfunction	Check for presence of the power supply; check that the fuses are not blown; in this case, identify the cause of the fault and then replace with versions with the same specifications.
ON	Serious malfunction	There is a serious malfunction; try switching off the control unit for a few seconds; if the condition persists, it means there is a malfunction and the circuit board has to be replaced.
1 flash per second	All is OK	Normal control unit operation
2 fast flashes	There has been a change in the status of the inputs	It is normal when there is a change to one of the inputs: STOP, OPEN, triggering of photocells or the radio transmitter is being used.
Series of flashes separated by a pause	Various	It is the same signal as for the flashing of 1 sec- (see Table 20)
STOP LED	Cause	Solution
OFF	Triggering or STOP input	Check the devices connected to the STOP input
OFF	All is OK	STOP input is active
STEP-by-STEP LED	Cause	Solution
OFF	All is OK	STEP-by-STEP input is inactive
ON	Triggering of STEP-by-STEP input	Normal if the device connected to the S.S. input is active
OPEN LED	Cause	Solution
OFF	All is OK	OPEN input is inactive
ON active	Triggering of OPEN input	Normal if the device connected to the OPEN input is active
CLOSE LED	Cause	Solution
OFF	All is OK	CLOSE input is inactive
ON	Triggering of CLOSE input	Normal if the device connected to the CLOSE input is active

TABLE 20 - LEDs on the control unit's keys

LED 1	Description
OFF	During normal operation the device indicates "Automatic Closing" is inactive.
ON	During normal operation the device indicates "Automatic Closing" is active.
Flashing	<ul style="list-style-type: none"> • Function programming in progress. • If it flashes together with L2, it means that the user must carry out the device recognition phase (refer to Paragraph 9.1.6)
LED 2	Description
OFF	During normal operation the device indicates "Close after photo" is not active.
ON	During normal operation the device indicates "Close after photo" is active.
Flashing	<ul style="list-style-type: none"> • Function programming in progress. • If it flashes together with L2, it means that the user must carry out the device recognition phase (refer to Paragraph "9.1.6 Recognition of the devices")
LED 3	Description
OFF	During normal operation the device indicates "Always close" is inactive.
ON	During normal operation the device indicates "Always close" is active.
Flashing	<ul style="list-style-type: none"> • Function programming in progress. • If it flashes together with L4, it means that the user must carry out the leaf length recognition phase (refer to Paragraph "6.4 Recognition of the length of the leaf").
LED 4	Description
OFF	During normal operation the device indicates "Standby" is inactive.
ON	During normal operation the device indicates "Standby" is active.
Flashing	<ul style="list-style-type: none"> • Function programming in progress. • If it flashes together with L3, it means that the user must carry out the leaf length recognition phase (refer to Paragraph "6.4 Recognition of the length of the leaf").
LED 5	Description
OFF	During normal operation the device indicates "Peak" is inactive.
ON	During normal operation the device indicates "Peak" is active.
Flashing	Function programming in progress.
LED 6	Description
OFF	During normal operation the device indicates "Pre-flashing" is inactive.
ON	During normal operation the device indicates "Pre-flashing" is active.
Flashing	<ul style="list-style-type: none"> • Function programming in progress.
LED 7	Description
OFF	During normal operation the device indicates that the CLOSE input activates a closing manoeuvre.
ON	During normal operation the device indicates that the CLOSE input activates a partial opening manoeuvre.
Flashing	Function programming in progress.
LED 8	Description
OFF	During normal operation the device indicates that SLIGHT is configured as Master.
ON	During normal operation the device indicates that SLIGHT is configured as Slave.
Flashing	Function programming in progress.

TECHNICAL CHARACTERISTICS OF THE PRODUCT

WARNINGS: • All technical specifications stated in this section refer to an ambient temperature of 20°C (± 5°C). • Nice S.p.a. reserves the right to apply modifications to products at any time when deemed necessary, maintaining the same intended use and functionality.

Technical characteristics SLH400	
Type	Electromechanical gear motor for the automatic movement of sliding gates for residential use, complete with electronic control unit
Pinion	Z: 15; Module: 4; Step: 12.6 mm; Primitive diameter: 60mm
Peak thrust [corresponding to the ability to develop a force capable of moving the leaf]	12Nm; corresponding to the capacity to move a leaf with a dynamic friction of up to 400N
Nominal torque [corresponding to the ability to develop a force capable of maintaining the movement of the leaf]	6Nm; corresponding to the capacity to move a leaf with a dynamic friction of up to 200N
Nominal torque speed	0.18m/s
Idling speed (the control unit allows 6 speeds to be programmed, approx. equal to: 100, 85, 70, 55, 45, 30%)	0.34m/s
Maximum frequency of operating cycles (nominal torque)	35 cycles / day (the control unit allows up to the maximum described in tables 2 and 3)
Maximum continuous operating time (nominal torque)	10 minutes
Operating limits	In general, SLIGHT is suitable for the automation of gates featuring weights of up to 400 kg or lengths of up to 6m as shown in Tables 1 and 2
Durability	Estimated between 20.000 cycles and 180.000 cycles, depending on the conditions reported in Table 3
SLIGHT power supply	230Vac (+10% -15%) 50/60Hz.
Thrust maximum absorbed power [equivalent to amperes]	330W
Insulation class	1 (a safety grounding system is required)
Emergency power supply	With PS124 optional accessory
Flashing light output	For 2 LUCYB flashing lights (12V, 21 W lamp)
Open Gate Indicator Output	For one 24V maximum 4W bulb (the output voltage may vary between -30 and +50% and can also control small relays)
BLUEBUS output	One output with a maximum load of 15 BlueBus units
STOP input	For normally open contacts, for 8,2KΩ; constant resistance, or normally closed contacts; with selfrecognition (any variation from the memorized status causes the "STOP" command)
Step-by-step Input	For normally open contacts (the closing of the contact causes the "STEP-BY-STEP" command)
OPEN input	For normally open contacts (the closing of the contact causes the "OPEN" command)
CLOSE input	For normally open contacts (the closing of the contact causes the "CLOSE" command)
Radio connector	"SM" connector for SMXI and SMXIS receivers
Radio AERIAL Input	52Ω for RG58 or similar type of cable
Programmable functions	8 ON-OFF functions and 8 adjustable functions (see tables 7 and 9)
Self-Recognition functions	Automatic identification of devices connected with the BlueBus outlet Self-recognition of the type of "STOP" device (Normally Open, Normally Closed contact or 8,2KΩ) Self-recognition of the gate length and calculation of the deceleration points and the partial opening point.
Operating temperature	-20°C ÷ 50°C
Use in acid, saline or potentially explosive atmosphere	No
Protection class	IP 44 on the finished product if installed according to proper installation criteria
Dimensions and weight	131x135xh405; 6.5 kg

CE MARK DECLARATION OF CONFORMITY and declaration of incorporation of partly completed machinery

Declaration in accordance with the following Directives: 2004/108/EC (EMC); 2006/42/EC (MD) annex II, part B

Note - The content of this declaration corresponds to the declaration at the last available version of the document filed in the offices of Nice S.p.A. prior to the printing of this manual. The text herein was re-adapted for editorial reasons. A copy of the original declaration can be requested from Nice S.p.A. (prov. of Treviso – Italy)

Declaration number: 473/SLH400

Revision: 0

Language: EN

Manufacturer's name: NICE S.p.a.

Address: Via Pezza Alta 13, Z.I. Rustignè, 31046 Oderzo (TV) Italy

**Person authorized
to provide technical**

Technical documentation: Nice s.p.a.

Type of product: Electromechanical gear motor with incorporated control unit

Model / Type: SLH400

Accessories: SMXI, SMXIS radio receiver; emergency battery: PS124

The undersigned Luigi Paro, as Managing Director, hereby declares under his own responsibility that the product identified above complies with the provisions of the following directives:

- DIRECTIVE 2004/108/EC OF THE EUROPEAN PARLIAMENT AND OF THE COUNCIL of 15 December 2004 on the approximation of the laws of the Member States relating to electromagnetic compatibility and repealing Directive 89/336/EEC, in accordance with following harmonised standards: EN 61000-6-2:2005, EN 61000-6-3:2007

In addition, the product conforms to the following directive in accordance with the provisions applicable to partly completed machinery:

- Directive 2006/42/EC OF THE EUROPEAN PARLIAMENT AND COUNCIL of May 17 2006 regarding machines and amending directive 95/16/EC (consolidated text)

- I hereby declare that the pertinent technical documentation has been drafted in accordance with Annex VII B of Directive 2006/42/EC and that the following essential requirements have been fulfilled: 1.1- 1.1.2- 1.1.3- 1.2.1-1.2.6- 1.5.1- 1.5.2- 1.5.5- 1.5.6- 1.5.7- 1.5.8- 1.5.10- 1.5.11

- The manufacturer agrees to send the national authorities pertinent information on the partly completed machinery, in response to a motivated request, without affecting its intellectual property rights.

- If the partly completed machinery is operated in a European country with an official language other than the language used in this declaration, the importer must include a translation with this declaration.

- The partly completed machinery must not be operated until the final machine in which it is to be incorporated is declared to conform to the provisions of Directive 2006/42/EC, if applicable.

The product also complies with the following standards:

EN 60335-1:2002 + A1:2004 + A11:2004 + A12:2006 + A2:2006 + A13:2008+ A14:2010 + A15:2011

EN 60335-2-103:2003+A1:2009

The parts of the product which are subject to the following standards comply with them:

EN 13241-1:2003, EN 12445:2002, EN 12453:2002, EN 12978:2003

Oderzo, 24 May 2013

Luigi Paro
(Managing Director)



Operation manual

(to be given to the final user)

IMPORTANT – This instruction sheet contains important information regarding safety; take care to read all instructions before using the product. Keep this manual in a safe place to enable future use.

SAFETY WARNINGS AND PRECAUTIONS

NEVER touch parts of the automation while the gate is moving!

- Before using the automation for the first time, take care to read this operation manual provided by the automation installer. Also ensure that you are fully informed of all origins of residual risks.

- Keep the manual for consultation when in doubt and ensure supply to new owners of the automation.

- Your automation is a machine that performs commands imparted by the user; negligent or improper use may constitute a hazard. Never activate automation controls if persons, animals or objects are present in the operating range.

- **Children:** this automation system guarantees a high level of safety, using special detection devices to prevent movement in the presence of persons or objects . thereby guaranteeing constant foreseeable and safe activation. However, it is advisable to ensure that children do not play in the vicinity of the automation. To avoid inadvertent activation, and remote controls should always be kept out of reach. (the transmitter is not a toy!).

- Check the automation frequently to detect possible imbalance, signs of wear or damage. Suspend use immediately if maintenance is required.

- Periodically check correct operation of the photocells and perform the scheduled maintenance at least every six months.

- Photocells do not constitute actual safety devices, but safety aids. They are designed using highly reliable technology, but in extreme conditions may be subject to malfunctions or potential faults. **CAUTION!**– In certain cases these faults are not immediately evident.

Never pass the transit area while the gate is moving!

- If any anomalous condition is noted on the automation, disconnect the power supply from the system immediately. Never attempt to repair the automation alone; contact your local installer for assistance. In the meantime the system can be used with manual Opening and Closing by manually releasing the gearmotors as described in this manual.

- In the event of a power failure, on restoral of power the first manoeuvre command will be executed at low speed, regardless of the type of speed set.

- Even if you possess the skills, never modify the system or automation programming and adjustment parameters: This is the responsibility of the automation installer.

- Testing, periodic maintenance and any repairs must be documented by the person performing the operations and the relative documents must be kept by the system owner.

- At the end of the automation's lifetime, ensure that it is disposed by qualified personnel and that the materials are recycled or scrapped according to current standards in the place of use.

MANUAL MOVEMENT AND RELEASE: before carrying out this operation please note that release can only occur when the leaf is stopped.

1 Slide the lock cover disc.

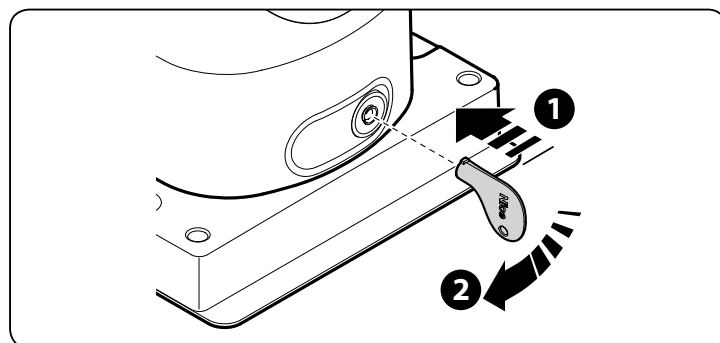

2 Move the leaf manually.

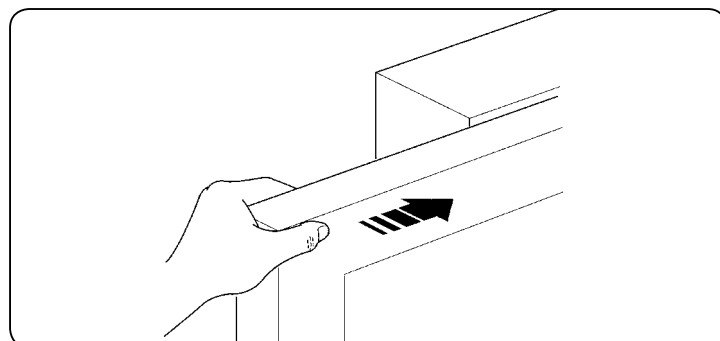

To lock: carry out the same procedures backwards.

Control with safety devices out of order: If the safety devices are malfunctioning, it is still possible to control the gate.

- Operate the gate control device (remote control or key-operated selector switch, etc.). If the safety devices enable the operation, the gate will open and close normally, otherwise the flashing light flashes a few times but the manoeuvre does not start (the number of flashes depends on the reason why the manoeuvre is not enabled).
- In this case, **actuate the control** again within 3 seconds and keep it actuated.
- After approximately 2s the gate will start moving in the “man present” mode, i.e. so long as the control is maintained the gate will keep moving; as soon as the control is released the gate will stop.

IMPORTANT! - If the safety devices are out of order the automation must be repaired as soon as possible.

Replacing the Remote Control Battery: if your radio control, after a period of time, seems not to work as well, or not to work at all, it may simply be that the battery is exhausted (depending on the type of use, it may last from several months up to one year and more). In this case you will see that the light confirming the transmission is weak, or does not come on, or comes on only briefly. Before calling the installation technician try exchanging the battery with one from another operating transmitter: if the problem is caused by a low battery, just replace it with another of the same type.

The batteries contain polluting substances: do not dispose of them together with other waste but use the methods established by local regulations.

Are you satisfied? If you wish to install another automation system in your home, call your old installation technician and use Nice products. You will get the services of a specialist and the most advanced products available on the market, superior performances and maximum system compatibility. Thank you for reading these instructions. We feel confident that you will be well satisfied with your new system: for any present or future requirements, please contact your reliable installation technician.



Nice SpA
Oderzo TV Italia
info@niceforyou.com

www.niceforyou.com